



## Electricity Specification 391

Issue 2

November 2012

# Actuator Requirements for Distribution Switchgear Automation

## Contents

- 1 Foreword
  - 2 Introduction
  - 3 Scope
  - 4 Definitions
  - 5 General Requirements for Approvals and Testing
  - 6 Requirements for Type and Routine Testing
  - 7 Physical Requirements
  - 8 Functional Requirements
  - 9 Installation
  - 10 Type Testing
  - 11 Drawings and Maintenance Instructions
  - 12 Disposal of Actuators and/or its Components
  - 13 Manual Handling
  - 14 Failure Modes, Effect and Cause Analysis (FMECA)
  - 15 Documents Referenced
  - 16 Keywords
- Appendices A and B

Approved for issue by the

Technical Policy Panel

© 2012 Electricity North West Limited.

All Rights Reserved

The copyright of this document, which contains information of a proprietary nature, is vested in Electricity North West Limited. The contents of this document may not be used for purposes other than that for which it has been supplied and may not be reproduced, either wholly or in part, in any way whatsoever. It may not be used by, or its contents divulged to, any other person whatsoever without the prior written permission of Electricity North West Limited.

### Issue and Amendment Summary

Amendment No. Date	Brief Description and Amending Action
0  16/10/01	Issue 1  First Issue  Prepared by: Roger Sumner Authorised by:
0  08/11/12	Issue 2  Document Updated to current template. Document altered to incorporate all types of actuators currently used on the ENW Network.  Prepared by: M A Kayes  Approved by the Technical Policy Panel and signed on its behalf by: Paul Whittaker

Amendment No. Date	Brief Description and Amending Action



## ACTUATOR REQUIREMENTS FOR DISTRIBUTION SWITCHGEAR AUTOMATION

### 1. FOREWORD

This specification sets out the technical requirements for the purchase of Distribution Switchgear Actuators by Electricity North West Ltd (hereafter referred to as Electricity North West) for connection to its Network.

### 2. INTRODUCTION

Electricity North West has implemented automation and remote control onto its 11kV and 6.6kV Network in order to reduce customer minutes lost and customer interruptions, and so improve the quality of supply to its customers. This can be achieved in a cost-effective manner by adding actuators with Remote Terminal Units (RTU) and communications facilities to existing switches (ring switches only on ring main units).

### 3. SCOPE

- 3.1 The purpose of this document is to specify Electricity North West's requirement for actuator kits for the Distribution Switchgear to provide automation and remote control facilities.
- 3.2 The functional requirements for actuators specified in this document can be applied to all types of Distribution Switchgear.
- 3.3 The preferred option shall always be the Switchgear Manufacturers own Actuator. Alternatives shall be subject to Approval by the Electricity North West Plant Policy Manager. The full list of approved Actuators can be found in Electricity Policy Document (EPD) 307.

#### 4. DEFINITIONS

- Approval:** Sanction by the Electricity North West Plant Policy Manager that specified criteria have been satisfied.
- Contract:** The agreement between Electricity North West and the Contractor for the execution of the Works including therein all documents to which reference may properly be made in order to ascertain the rights and obligations of the parties under the said agreement.
- Contractor:** The person or person's firm or company, including personal representatives, successors and permitted assigns, whose tender has been accepted by Electricity North West.
- Specification:** The Specifications and schedules (if any) agreed by the parties for the purpose of the Contract.
- Sub-Contractor:** Any person (other than the Contractor) named in the Contract for any part of the Works or any person to whom any part of the Contract has been sub-let with the consent in writing of the Electricity North West Plant Policy Manager, and the legal representatives, successors and assigns of such person.
- Supplier:** Any person or person's firm or company who supplies goods to Electricity North West or to its contractor.
- Tender:** An offer in writing to execute work or supply goods at a fixed price.
- Tenderer:** The person or person's firm or company, including personal representatives, successors and permitted assigns, invited by Electricity North West to submit a tender.

## **5. GENERAL REQUIREMENTS FOR APPROVALS AND TESTING**

### **5.1 Product not to be Changed**

No change in the product, packaging or labelling shall be made after Approval has been granted without prior notice to the Electricity North West Plant Policy Manager, and receipt of a written agreement to the proposed change from the Electricity North West Plant Policy Manager.

### **5.2 Electricity North West Technical Approval**

5.2.1 The Tenderer shall submit, with this Tender, proposals for testing which will demonstrate, to the satisfaction of the Electricity North West Plant Policy Manager, compliance with this Specification. Such tests shall be carried out without expense to Electricity North West.

5.2.2 Alternatively, the Tenderer may submit technical reports and other data that he considers will demonstrate, to the satisfaction of the Electricity North West Plant Policy Manager, compliance with this specification. Acceptance of this evidence shall be at the discretion of the Electricity North West Plant Policy Manager but will not be unreasonably withheld.

5.2.3 Approval shall be 'factory specific' and is not transferable to another factory without the written approval of the Electricity North West Plant Policy Manager.

5.2.4 The supplier and product shall comply with all the relevant requirements of Electricity North West documents EPD311 and CP311.

### **5.3 Quality Assurance**

5.3.1 The Tenderer shall confirm whether or not approval is held in accordance with a Quality Assurance Scheme accredited under ISO 9000. If not, he shall submit a statement of the quality assurance procedures employed to control the quality of the product, including the performance of Suppliers and Sub-Contractors.

5.3.2 The right is reserved for the Electricity North West Plant Policy Manager to require, from time to time, the repeat of such tests as he may deem to be reasonably necessary to demonstrate continued compliance with the Specification.

5.3.3 The Tenderer shall submit, with his Tender, a list of tests and inspections which are carried out on the product prior to despatch which shall demonstrate, to the satisfaction of the Electricity North West Plant Policy Manager, fitness for installation and service.

5.3.4 The Tenderer shall provide free of charge to Electricity North West such samples as may, in the opinion of the Electricity North West Plant Policy Manager, be reasonably required for inspection and/or retention as quality control samples. The Electricity North West Plant Policy Manager will confirm the requirement for samples at the time of Tendering.

5.3.5 The right is reserved for the Electricity North West Plant Policy Manager to make, from time to time, such inspections of the Tenderer's facilities as he may deem to be reasonably necessary to ensure compliance with this Specification and any Contract of which it forms a part.

4.3.6 The Tenderer shall submit, with his Tender, such details of product packaging disposal, as will enable Electricity North West to comply with the requirements of BS EN ISO 14001: 2004 - Environmental Management Systems.

#### **5.4 Formulation**

The Tenderer shall submit, with his Tender, such details of the formulation and use of the product and associated substances as will enable Electricity North West to comply with the obligations of the Health and Safety at Work Act 1974 and the Control of Substances Hazardous to Health Regulations 2002, in the use, storage and disposal of the product. The Tenderer may stipulate, prior to submission of such information, that he requires it to remain confidential and the Electricity North West Plant Policy Manager will, if requested, confirm his agreement to this prior to receipt of the information.

#### **5.5 Identification Markings**

5.5.1 The Tenderer shall submit, with his Tender, details of markings which it is proposed to apply to the product or packaging to identify manufacturing batches or items. The forms and content of such markings shall be subject to the Approval of the Electricity North West Plant Policy Manager, and shall in all cases include the Electricity North West Approved Description and Commodity Code Number.

5.5.2 The Tenderer shall submit, with his Tender, such details of marking gross weight on components, assemblies and packages, as will enable Electricity North West to comply with the Health and Safety Manual Handling Operation Regulations 1992, for components, assemblies and packages supplied with a gross weight over 1kg. The forms and content of such markings shall be subject to the Approval of the Electricity North West Plant Policy Manager.

#### **5.6 Minimum Life Expectancy**

The minimum life expectancy of all products covered by this Specification is 40 years.

#### **5.7 Product Conformity**

Preference will be given to those suppliers who can provide suitable Product Conformity Certification to a recognised or specified standard, or an equivalent certification.



## **6. REQUIREMENTS FOR TYPE AND ROUTINE TESTING.**

The Electricity North West Plant Policy Manager shall set out the requirement of the following tests to be carried out by the Supplier at the Supplier's cost.

### **6.1 Requirement for Type Tests at the Supplier's Premises**

These are a series of one-off type tests, which are carried out to ensure the satisfactory performance of the product design, under extremes of operating stresses, and of endurance, as may be appropriate, to be determined by the Electricity North West Plant Policy Manager.

These may or may not be destructive tests.

### **6.2 Requirement for Routine Tests at the Supplier's Premises**

These tests may be required to be carried out on every individual unit or component, as specified, or at some regular frequency to be determined by the Electricity North West Plant Policy Manager.

The results of these tests may be required to be supplied to Electricity North West with each unit purchased or retained for inspection, at a period to be determined by the Electricity North West Plant Policy Manager.

## **7. PHYSICAL REQUIREMENTS**

The actuator kit shall work in conjunction with a RTU fitted at each automated or remotely controlled point - see Figure 1 in appendix A.

An actuator kit shall comprise two distinct parts:

- Actuator
- Control circuits

### **7.1 Actuator**

7.1.1 The actuator shall be in a housing suitable for outdoor applications, rated to IP55 of BS EN 60529:1992 and shall be corrosion and vandal resistant. When fitted, the housing shall preferably allow for manual operation or maintenance of the switch without removing the Actuator. It shall be so constructed that the switch position indicator is visible at all times. Where only one switch on the Ring Main Unit is actuated the actuator shall not impede manual operation of the non-actuated switch.

7.1.2 The cover should be secured in such a way that no special tools are required to remove it and a padlock facility should be provided.

7.1.3 Manual operation of the actuated switch may be by a manual operating handle. The handle interface shall be behind a separate lockable cover on the Actuator. Under such conditions the actuator shall remain substantially mounted and secure.

- 7.1.4 The actuator shall be designed such that its operating speed and energy shall not cause any over-stressing of the switch to which it is fitted. It shall also have suitable springs and/or freedom of travel such that any overtravel in the switchgear spring operating mechanism does not cause undue stress.
- 7.1.5 A multicore cable shall be provided to connect the actuator to the control circuits. Use of plugs and sockets to allow quick connection on site shall be considered.

## **7.2 Control Circuits**

- 7.2.1 The control circuits may be housed in the RTU, or alternatively they may be incorporated in the enclosure that houses the actuator. In either case space should be provided for RTU and communications equipment that may be provided by others.
- 7.2.2 The circuits shall comprise on/off and local remote switches and additional circuitry to provide any necessary interlocks and facilities for remote control and indications.
- 7.2.3 A Miniature Circuit Breaker (MCB) shall be provided to isolate the 240V low voltage supply to the Actuator / RTU. This MCB shall be lockable in the off position.
- 7.2.4 Both parts shall be capable of operating in the normal service condition specified in Clause 1.2.1 of Energy Networks Association (ENA) Technical Specification (TS) 41-36 and shall be able to operate from a 12V or a 24V DC supply.
- 7.2.5 The Actuator and RTU may be housed separately or in the same enclosure.

## **8. FUNCTIONAL REQUIREMENTS**

### **8.1 Control**

With an Actuator fitted to a switching device it shall be possible to operate the device in the following manner:-

- 8.1.1 Locally by electrical operation using the switches / pushbuttons, or by manual operation.
- 8.1.2 Remotely - electrical operation by telecontrol, or the automation system.
- 8.1.3 A local/remote selector switch shall allow either of these options to be selected, with the normal operating mode being 'remote' via automation or telecontrol.
- 8.1.4 In the case of either local or remote control, both open and close facilities are required. The required actuator driven switching actions are therefore from OFF to ON and from ON to OFF. The switching between the EARTH OFF and EARTH ON positions and vice versa shall in all cases remain a manual operation.

## 8.2 Operation

### 8.2.1 Manual Operation

The manual operating handle must remain common to all switches and must ensure a 3 second delay between operations. The manual operation shall also comply with the Switchgear manufacturer's open and close times. The Tenderer shall supply the operating times with their Tender.

### 8.2.2 Electrical Operation

If an actuator stops part way through an operation leaving it in a mid travel position, then the operation sequence shall stop. In the event of the supplies being restored the actuator shall not automatically complete its operation. The switch shall be able to be returned to its start position or complete its original operation as decided by the operator. The design of the actuator and control mechanism shall allow the actuator to be reset without disassembly of the unit (e.g. it shall be reset electrically).

The electrical operation shall ensure a 3 second delay between operations. The electrical operation shall also comply with the Switchgear manufacturer's open and close times. The Tenderer shall supply the operating times with their Tender.

## 8.3 Indications

8.3.1 Position indication of the main switch shall be provided by switches operated directly off the switch shaft or via part of the actuator mechanism fixed directly to the shaft such that indication is not affected by failure of the actuator mechanism. Position indication derived from the operating mechanism of the actuator is not acceptable.

8.3.2 Status indication of the earth switch or the interlock is not required.

## 8.4 Interlocks

8.4.1 Remote control/automatic operation of the actuator shall not be possible with the actuator cabinet and/or RTU door open or cover removed.

8.4.2 Interlock facilities shall prevent reverse operation of the switch within three seconds of the original operation to prevent opening of devices within the operating time of protection systems.

8.4.3 Suitable interlocks shall be provided such that it is not possible to connect an operating handle without the electrical control being disabled. Isolation of the power supply to the actuator prime mover shall be via removable fuse and link providing double pole isolation.

8.4.4 Suitable means of ensuring that the actuator cannot be driven against the Off/Earth interlock must be provided. This is to prevent damaging the switchgear should the interlock be left in the incorrect position for the subsequent operation. Electrical means of ensuring the actuator motor is not over stressed will not be considered as a solution, although this should be provided.

## **8.5 Locking**

It shall be possible to safety lock the mechanism of the main switch in both the open and closed positions at all times. It shall also be possible to lock the local/remote switch in either position and the MCB in the off position. Means of ensuring the motor does not drive against a lock or means of ensuring the actuator motor is not overstressed if driven against the lock shall be provided.

## **9. INSTALLATION**

- 9.1 The actuator and control circuits shall be provided as a complete kit with all necessary installation materials. It is likely that the control circuits will be free-issued to the RTU supplier for installation in the factory where-as the actuator will be free-issued for installation on site.
- 9.2 It shall be possible to install the actuator safely on site with the switchgear energised and without the need to open or drill the tank.
- 9.3 The actuator kit supplier shall specify the requirements for mounting the actuator on site including any special tools and equipment and shall provide full installation, operation and maintenance instructions. A laminated instruction sheet must be affixed inside the door of all cabinets following installation.
- 9.4 The installation of housings must not prevent the use of any operating platform or storage/locking facility for operating handles. Modifications to existing arrangements shall be subject to Approval by the Electricity North West Plant Policy Manager.

## **10. TYPE TESTING**

The manufacturer shall submit to Electricity North West any ENA Switchgear Assessment Panel Notice of Conformity Certificates and any pre-existing independent type test certification. The Actuator kit shall be type tested to a minimum of 500 OFF - ON - OFF operations each time confirming the operation is within the rated operating time.

## **11. DRAWINGS AND MAINTENANCE INSTRUCTIONS**

General arrangement drawings shall be submitted with the Tender. These drawings shall include as a minimum overall dimensions of the Actuator, headroom for erection and/or operation, space required for removal and positions of mains and multicore cables.

On receipt of an order the Contractor shall submit drawings at an early stage on CD-Rom in an AutoCAD (.dwg) and Adobe Acrobat (pdf) format and one paper print maximum size A1 of all diagrams to the Electricity North West Plant Policy Manager.

A copy of all installation, operation and maintenance manuals shall be submitted with the tender. These manuals shall, preferably, be on a CD-Rom in Adobe Acrobat (pdf) format.

If the Actuator is of a type not previously supplied to Electricity North West, one unit will be required to be delivered to the Electricity North West Training Centre, free of charge, for the purposes of training. The Tenderer will also be required to provide training for Electricity North West instructors on the operation of the unit.

An Operation, Installation and Maintenance Manual shall also be supplied with the Tender.

**12. DISPOSAL OF ACTUATORS AND/OR ITS COMPONENTS**

Tenderers shall provide details on how to dispose of the Actuator and/or its components to ensure compliance with the various waste management regulations [Environmental Protection Act 1990 (Part II); Special Waste Regulations 1996; Waste Management Licensing Regulations 1994; Control of Pollution (Amendment) Act 1989]

**13. MANUAL HANDLING**

Tenderers shall supply a Risk Assessment on the manual handling required for installation and operation of the Actuator.

**14. FAILURE, MODES, EFFECT AND CAUSE ANALYSIS (FMECA)**

Tenderers shall carry out a FMECA or equivalent study for each type of equipment offered. A copy of this study shall be provided with the tender documents.

**15. DOCUMENTS REFERENCED**

Health and Safety at Work Act 1974

Control of Substances Hazardous to Health Regulations 2002

Manual Handling Operations Regulations 1992

Environmental Protection Act 1990

Special Waste Regulations 1996

Waste Management Licensing Regulations 1994

Control of Pollution (Amendment) Act 1989

BS EN 60529:1992      Degrees of Protection provided by Enclosures (IP Code)

ENA TS 41-36      Distribution Switchgear for Service up to 36kV (Cable and overhead conductor Connected)

**16. KEYWORDS**

Actuator;

Automation;

CML;

APPENDIX A

Key

————— To be provided by actuator supplier

..... May be provided by others

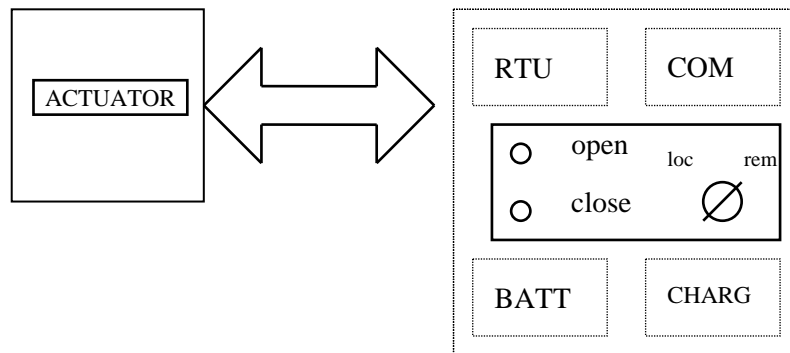

Figure 1      Actuator and Control System

**APPENDIX B**

**SELF CERTIFICATION CONFORMANCE DECLARATION**

**CLAUSE BY CLAUSE CONFORMANCE WITH THIS ES**

The manufacturer shall declare conformance or otherwise, clause by clause, using the following levels of conformance declaration codes.

Conformance declaration codes

- N/A = Clause is not applicable/appropriate to the product/service
- C1 = The product/service conforms fully with the requirements of this clause
- C2 = The product/service conforms partially with the requirements of this clause
- C3 = The product/service does not conform to the requirements of this clause
- C4 = The product/service does not currently conform to the requirements of this clause, but the manufacturer proposes to modify and test the product in order to conform.

**Manufacturer:**

**Product/Service  
Description**

**Product /Service  
Reference :**

Assessor

Name	Company	Signature	Date
------	---------	-----------	------

Clause/Sub- Clause		Requirement	Conformance Code	Remarks  (Must be completed if Conformance Code is not C1)
5	1	Product not to be Changed		
5	2	Electricity North West Technical Approval		
5	3	Quality Assurance		
5	4	Formulation		
5	5	Identification Marking		
5	6	Minimum Life Expectancy		
5	7	Product Conformity		
6	1	Requirement for Type Tests at the Suppliers' Premises		
6	2	Requirement for Routine Tests at the Suppliers' Premises		
7		Physical Requirements		
7	1	Actuator		
7	2	Control Circuits		
8	1	Control		
8	2.2	Manual Operation		
8	2.1	Electrical Operation		
8	3	Indications		



8	5	Locking		
9		Installation		
10		Type Testing		
11		Drawings and Maintenance Instructions		
12		Disposal of Actuators and/or its components.		
13		Manual Handling		
14		Failure Modes, Effect and Cause Analysis (FMECA)		

Additional Notes: