

PRODUCED BY THE OPERATIONS DIRECTORATE OF ENERGY NETWORKS ASSOCIATION

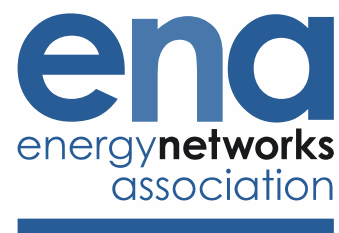

Engineering Recommendation G100

Issue 2 2022 Amendment 2

Technical Requirements for Customers' Export
and Import Limitation Schemes

PUBLISHING AND COPYRIGHT INFORMATION

© 2023 Energy Networks Association

All rights reserved. No part of this publication may be reproduced, stored in a retrieval system or transmitted in any form or by any means, electronic, mechanical, photocopying, recording or otherwise, without the prior written consent of Energy Networks Association. Specific enquiries concerning this document should be addressed to:

**Operations Directorate
Energy Networks Association
4 More London Riverside
London
SE1 2AU**

This document has been prepared for use by members of the Energy Networks Association to take account of the conditions which apply to them. Advice should be taken from an appropriately qualified engineer on the suitability of this document for any other purpose.

First published, July 2016

Amendments since publication

Issue	Date	Amendment
Issue 1	July 2016	First issue
Issue 1 Amnd 1	March 2017	Revision to the following sections/appendices to enable fast track application process for ERG83 Energy Storage Systems. 5.2.3 – Voltage Assessment 7.4 – Fail Safe Tests Appendix B – Information to be provided relating to Fail Safe Tests
Issue 1 Amnd 2	May 2018	Introduction of a new Appendix C – Manufacturers G100 product declaration
Issue 2	May 2022	Completely revised and reissued as Issue 2.
Issue 2 Amnd 1	July 2022	A sentence clarifying automatic reset for communication failures added to 4.5.2.2. Minor editorial corrections, and clarifications, made to Examples 1, 3, 4 and 5 in Appendix E.
Issue 2 Amnd 2	April 2023	Deletion of state 3 voltage limits: changes to 1; 4.2; 4.3.3; 5.6; 5.6.3; Appendix B and the deletion of 4.4.2.2 and 5.6.3.3 – 5.6.3.10 (and subsequent paragraphs renumbered).

		<p>Guidance on multiple devices with diversity: changes to 4.4, 4.5.3; 4.5.3.2 and Example 7.</p> <p>Harmonization of failure detection times: changes to 4.3.2; 4.3.3; 4.5.1.1; 4.5.1.2; 4.5.1.3.</p> <p>Obviation of state 3 for comms failures: additional text in 4.5.1.2.</p>
--	--	--

Contents

Foreword.....	6
Introduction	7
1 Scope	8
2 Normative references.....	9
3 Terms and definitions.....	10
4 Requirements	12
4.1 Concept	12
4.2 General CLS Features	13
4.3 Operational States	14
4.4 Design Limits	15
4.5 Fail Safe	17
4.6 Communications	21
4.7 Cyber security.....	21
4.8 Access to DNOs' Current and Voltage Signals.....	22
4.9 Generation in Non-exporting Sites	22
4.10 Multiple CLSs in a Single Installation	22
4.11 Domestic Installations	23
4.12 Interfaces with DNOs' Systems.....	23
5 Application and Acceptance.....	24
5.1 General.....	24
5.2 Site commissioning of Fully Type Tested CLSs	24
5.3 Commissioning Sequence	25
5.4 Preventing the Limits Being Exceeded During Testing and Commissioning.....	25
5.5 Fail Safe Tests.....	25
5.6 Operational tests.....	27
5.7 Overload and Reverse Power Protection	30
6 Ongoing Obligations	30
7 Manufacturers' CLS Product Declarations.....	31
Appendix A- CLS Application Information.....	32
Appendix B – Manufacturer's CLS Product Information	34
Appendix C – CLS Installation and Commissioning Tests	40
Appendix D – Examples	44

Figures

Figure 0-1 Operational State Concept	7
Figure 4-1 Conceptual Representation of a CLS	13
Figure 4-2 – Excursions into State 2 counting towards the excursion limit.....	19
Figure 5-1 – Current Step Tests	28

Figure E 1 - Large PV Installation at a Domestic property	44
Figure E 2 - Wind Turbine Installation at a Farm.....	46
Figure E 3 – New PV Farm.....	48
Figure E 4 Domestic EV Charging.....	51
Figure E 5 Commercial EV Charging.....	53
Figure E 6 Overload Protection Option (a).....	54
Figure E 7 Overload Protection Option (b).....	55

Tables

Table 5-1 - Test Sequence.....	26
Table 5-2 – List of Tests.....	29

Foreword

This Engineering Recommendation (EREC) is published by the Energy Networks Association (ENA) and comes into effect from the date of publication. It has been prepared under the authority of the ENA and has been approved for publication by the ENA's Electricity Networks and Futures Group (ENFG). The approved abbreviated title of this engineering document is "EREC G100".

This revised EREC G100 Issue 2 is an extensive revision of Issue 1, incorporating a new specific approach to defining the criteria that determine the behaviour of **Customer's** limitation schemes, and the sizes of generation and/or demand that can be installed under the control of such schemes.

Following publication of EREC G100 Issue 2, a minor omission and small number of editorial mistakes have been found. These have been corrected in this EREC G100 Issue 2, Amendment 1. Amendment 2 removes the voltage triggers for state 3 operation and makes other minor changes as listed on page 2 of this document. **CLSs Type Tested** to Issue 2 Amendment 1 will be treated as compliant with the requirements of Issue 2 Amendment 2.

EREC G100 Issue 2 supersedes EREC G100 Issue 1 Amendment 2 "Technical Requirements for Customers Export and Import Limitation Schemes". However **Manufacturers** and **Installers** will need time to ensure their products and installations meet the new requirements. Hence compliance with Issue 2 Amendment 1 will be optional on its first introduction until 01 May 2023 when it will become mandatory, and Issue 1 Amendment 2 will be withdrawn. **Customers** will therefore be able to choose to comply (in full) with either EREC G100 Issue 1 Amendment 2 or EREC G100 Issue 2 Amendment 1 for **Customers' Export and Import Limitation Schemes (CLSs)** which manage export commissioned before 01 May 2023. **CLSs** which manage import commissioned after 01 May 2023 shall comply with this EREC G100 Issue 2 Amendment 1.

This document applies to both **Customer's** export and import limitation schemes.

NOTE: Commentary, explanation and general informative material is presented in smaller type and does not constitute a normative element.

Introduction

The purpose of this Engineering Recommendation (EREC) is to state the requirements for **Customer Export or Import Limitation Schemes (CLS)** that are used to limit the export to and/or the import from the **Distribution Network** of a licensed **Distribution Network Operator (DNO)**.

The guidance given is designed to facilitate the use of **CLSs** whilst maintaining the integrity of the **Distribution Network**, both in terms of safety and supply quality.

Customers are becoming increasingly aware of environmental issues and are seeking to install low carbon technology **Devices**, such as heat pumps, electric vehicle charging points and photovoltaic generation within their premises that might add significant load and/or generation (including electricity storage) on to **Distribution Networks**. Where the **DNO** has assessed that connection of such **Devices** will require costly reinforcement, or reinforcement that would take time to implement thus delaying the connection, some **Customers** may choose to restrict the net flows of electricity at their **Connection Point** rather than wait for, or contribute to, the reinforcement.

A typical **CLS** may be used in the following scenarios:

- Installing generation with an aggregate **Current Rating** greater than the permitted export to the network and limiting the peak export;
- Connecting significant new loads which cannot operate at their full capacities at the same time without exceeding the import capacity from the network;
- Using the flexibility of the **Customer's** loads and generation to stay within import or export limits.

The use of a **CLS** is not intended to interfere with any load or generation flexibility that **Customers** wish to make use of. Instead its function is to ensure that the **Customer's Devices** do not impose current flows on the **Distribution Network** which are greater than the **MEL** or **MIL** as agreed in the **Connection Agreement**. This is illustrated for the current flow at the **Connection Point** of an example installation in Figure 0-1 below.

Figure 0-1 Operational State Concept

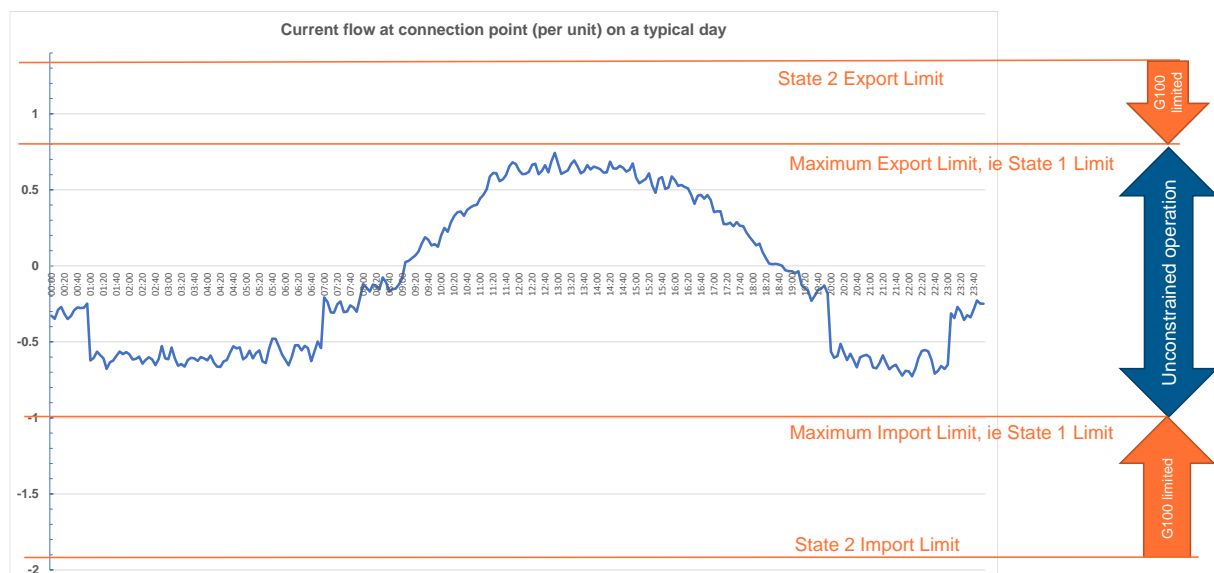

As well as complying with this EREC G100 all **Customer's Installations** shall comply with the Distribution Code and its Annex 1 documents, particularly EREC G5, EREC P28 and EREC P29. Installations with generation shall also comply with EREC G59, EREC G83, EREC G98 or EREC G99 as appropriate.

1 Scope

This document applies to all in **Customers' Installations** connected at any voltage, where new load or generation equipment is commissioned on or after 01 May 2023¹, such that there is an agreed need to restrict the flow of current at the **Connection Point** or to prevent voltage limits on the **Distribution Network** from being exceeded. This may require the installation of a **CLS** or suitable overload or reverse power protection. For the avoidance of doubt, normal limitations on the connection or the operation of generation due to fault level exceedance will apply.

The focus of this document is **Customers' Installations** connected at voltages up to and including 20kV. The same principles will be applied for installations connected above this voltage. However in these cases the **DNO** may vary the exact requirements to suit the particular network characteristics at that location.

This document does not apply:

- where the aggregate **Current Rating** of the generation is less than the **MEL**; or
- where the sum of the **Current Rating** of both
 - the uncontrolled loads after making an appropriate allowance for diversity²; and
 - the relevant controllable loadsconnected in the installation is less than the **MIL**.

A **CLS** may not be compatible with some flexible connections. For example, in a network managed by an active network management system, a **CLS** might interact with the instructions issued by the active network management system thus restricting deployment. It will be the responsibility of the **DNO** to assess the suitability of a **CLS** in these situations and liaise with the **Customer** accordingly.

The requirements for **CLSs** in this EREC G100 assumes that the **CLS** will, or may be, controlling both import and export. Where it is certain that by design the **CLS** will only ever control one of these, then this shall be clearly indicated in the information provided by the **Manufacturer** or **Installer**. In these cases, for import only limitation schemes the export current can be ignored or omitted, and for export only limitation schemes import current can be ignored or omitted.

As an alternative to complying fully with all the EREC G100 requirements for a **CLS**, where the **DNO** and the **Customer** agree that there is a risk of current flows at the **Connection Point** breaching either the **MEL** or **MIL**, the **Customer** may elect to install overload

¹ The use of this issue of EREC G100 for the design and implementation of **Customers'** export or import limitation schemes is not precluded before that date.

² As described in BS7671 and/or its guidance document "IET 18th Edition On-Site Guide BS7671:2018 Wiring Regulations".

protection and/or reverse power protection that trips the whole of the **Customer's Installation** (or appropriate **Devices** as agreed with the **DNO**). In these cases:

- the **Customer's Installation** shall comply with the state 2 limits (see section 4.3.2) unless specifically agreed otherwise with the **DNO**;
- the **Customer's Installation** shall have the necessary overload protection and/or reverse power protection set as required by section 4.5.3.2; and
- the design and settings of the overload protection and/or reverse power protection will be agreed with the **DNO** and recorded in the **Connection Agreement**.

Reverse power protection will be appropriate where any generation within the **Customer's Installation** should never be able to export to the **DNO's Distribution Network**, ie where the **MEL** is zero.

2 Normative references

The following referenced documents, in whole or part, are indispensable for the application of this document. For dated references, only the edition cited applies. For undated references, the latest edition of the referenced document (including any amendments) applies.

Standards publications

BS 7671	18 th Edition – IET Wiring Regulations
ETSI EN 303 645	Cyber Security for Consumer Internet of Things: Baseline Requirements
Wiring Regs Guidance	IET 18 th Edition On-Site Guide BS7671:2018 Wiring Regulations
PAS 1879	Energy smart appliances – Demand side response operation – Code of practice

Other publications

Distributed Energy Resources – Cyber Security Connection Guidance
published by BEIS and the ENA.

Engineering Recommendation G5	Harmonic voltage distortion and the connection of harmonic sources and/or resonant plant to transmission systems and distribution networks in the United Kingdom
Engineering Recommendation G59	Recommendations for the connection of generation plant to the Distribution Systems of licensed Distribution Network Operators

Engineering Recommendation G83	Requirements for the connection of small scale embedded generators (up to 16A per phase) in parallel with Public Low Voltage Distribution Networks
Engineering Recommendation G98	Requirements for the connection of Fully Type Tested Micro-generators (up to and including 16 A per phase) in parallel with public Low Voltage Distribution Networks on or after 27 April 2019
Engineering Recommendation G99	Requirements for the connection of generation equipment in parallel with public Distribution Networks on or after 27 April 2019
Engineering Recommendation P28	Voltage fluctuations and the connection of disturbing equipment to transmission systems and distribution networks in the United Kingdom
Engineering Recommendation P29	Planning limits for voltage unbalance in the United Kingdom

3 Terms and definitions

Component

A discrete unit within the **Customer's Installation** that, together with other similar units which are in secure communication with each other, form the **CLS**.

Connection Agreement

A contract between the **DNO** and the **Customer**, which includes the relevant **Customer's Installation's** requirements and specific technical requirements for the **Customer's Devices**.

For **Domestic Installations** where there is no specific existing bilateral **Connection Agreement**, any agreement between the **Customer** and the **DNO** in relation to the requirements and operation of the **CLS** will be considered to be part of the National Terms of Connection³.

Connection Point

The interface at which the **Customer's Installation** is connected to a **Distribution Network**, as identified in the **Connection Agreement**. For the avoidance of doubt two or more connection circuits constitutes a single **Connection Point** for the purposes of this EREC G100.

Current Rating

The normal full load rating of a **Device**, expressed in amperes at the nominal voltage⁴ and at unity power factor. Where the **Device** includes generation (ie including storage **Devices**) the

³ <http://www.connectionterms.co.uk/>

⁴ Note – the term “nominal voltage” is used throughout this EREC G100 to refer to the normal system voltages used in GB. In some cases the **DNO** and the **Customer** will agree a non-standard voltage range at the **Connection Point**. In these cases, the relevant voltage shall be used instead of the normal or statutory values.

Current Rating shall not include any current which is required to operate the **Device**, ie that which supplies any parasitic loads directly associated with the **Device**⁵.

Customer

A person who is the owner or occupier of an installation or premises that are connected to the **Distribution Network**. For the purposes of EREC G100 the **Customer** includes any agent specifically authorised in writing by the **Customer** to act on the **Customer's** behalf.

Customer Export or Import Limitation Schemes (CLS)

A system comprising of one or more **Components** providing control signals that interface with the **Customer's** generation and/or load (ie the generation and load that is specifically intended to be controlled by the **CLS**, and referred to hereafter as the **Customer's Devices**) to control the net flow of electricity into or from the **Distribution Network** at the **Connection Point** so as not to exceed the **MEL** or **MIL**.

A **CLS** may be a single integrated unit (excepting transducer(s) at the **Connection Point**) or composed of a number of distributed discrete **Components**. In all cases the **CLS** is expected to include a **Component** that is a transducer that measures the current and voltage at the **Connection Point**.

Note that this latter **Component** could form part of another piece of equipment entirely, one that measures the values appropriately, and is not associated originally with the **CLS**, provided it fulfils the same function and is appropriately integrated into the **CLS's** overall behaviour (including appropriate secure and **Fail Safe** communications).

Customer's Installation

The electrical installation on the **Customer's** side of the **Connection Point** together with any equipment permanently connected or intended to be permanently connected thereto.

Device

Any significant load or generation equipment which is designed to be controllable by an external signal or set point. **Devices** can include equipment typically referred to as low carbon technologies, including renewable generation, electrical storage, heat pumps and electric vehicles. The term is used in relation to any such controllable load or generation installed in domestic, commercial and industrial installations.

Distribution Network

An electrical network for the distribution of electrical power from and to a third party(s) connected to it, a transmission network or another **Distribution Network**.

Distribution Network Operator (DNO)

The person or legal entity named in Part 1 of the Distribution Licence and any permitted legal assigns or successors in title of the named party. A distribution licence is granted under Section 6(1)(c) of the Electricity Act 1989 (as amended by the Utilities Act 2000 and the Energy Act 2004).

Domestic Installations

For the purposes of this EREC G100 those **Customer Installations** connected at **LV** (typically single phase, but not exclusively so) and with a capacity of no more than 100A.

⁵ **Current Rating** is equivalent to the Registered Capacity (as defined in EREC G98 and G99) at the nominal voltage and at unity power factor.

Fail Safe

A design requirement that enables the **CLS** to limit export or import at the **Connection Point** to the **MEL** or **MIL** respectively, irrespective of the failure of one or more its **Components** or the failure of any communications between the **CLS's Components** and **Devices**.

Fully Type Tested

A **CLS** which has been tested to ensure that the design meets the relevant technical and compliance requirements of this EREC G100, and for which the **Manufacturer** has declared that all similar **CLSs** supplied will be constructed to the same standards and will have the same performance.

High Voltage (HV)

A voltage of 1 000V or above.

Installer

The party who is responsible for installation of the **CLS** in the **Customer's Installation**. The equipment installed may be a **Fully Type Tested CLS** or a **CLS** that is assembled in the **Customer's Installation** from **Components**.

Low Voltage (LV)

A voltage less than 1 000V.

Manufacturer

The party responsible for the manufacture of **CLSs** deployed in **Customers' Installations** in Great Britain.

Maximum Export Limit (MEL)

The maximum current, as agreed between the **Customer** and the **DNO** which may be exported onto the **Distribution Network** via that **Connection Point**.

Maximum Import Limit (MIL)

The maximum current, as agreed between the **Customer** and the **DNO** which may be imported from the **Distribution Network** via that **Connection Point**.

Type Tested

A **CLS**, or a **CLS Component**, or part of a **Component** which has been tested to ensure that the design meets the relevant requirements of this EREC G100, and for which the **Manufacturer** has declared that all similar products supplied will be constructed to the same standards and will have the same performance. The **Manufacturer's** declaration will define clearly the extent of the equipment that is subject to the tests and declaration. The ENA provides a database, the Type Test Register, for **Manufacturers** to lodge their statements of compliance and supporting information.

4 Requirements

4.1 Concept

A **CLS** can control any number of **Devices**.

A **CLS** may comprise a single **Component**, communicating with one or more **Devices**, plus a **Component** which is a transducer at the **Connection Point**. Alternatively a **CLS** might comprise several discrete **Components** distributed in the **Customer's Installation** which communicate securely with each other and with the **Devices** they are controlling.

A **CLS** might be included as a functional feature in any **Device**, with the capability to measure the magnitude of current and direction of power flows at the **Connection Point**.

However the **CLS** is constructed and implemented, it shall have the characteristics and capabilities as described in this EREC G100.

Conceptually the **CLS** can be represented Figure 4-1.

Figure 4-1 Conceptual Representation of a CLS

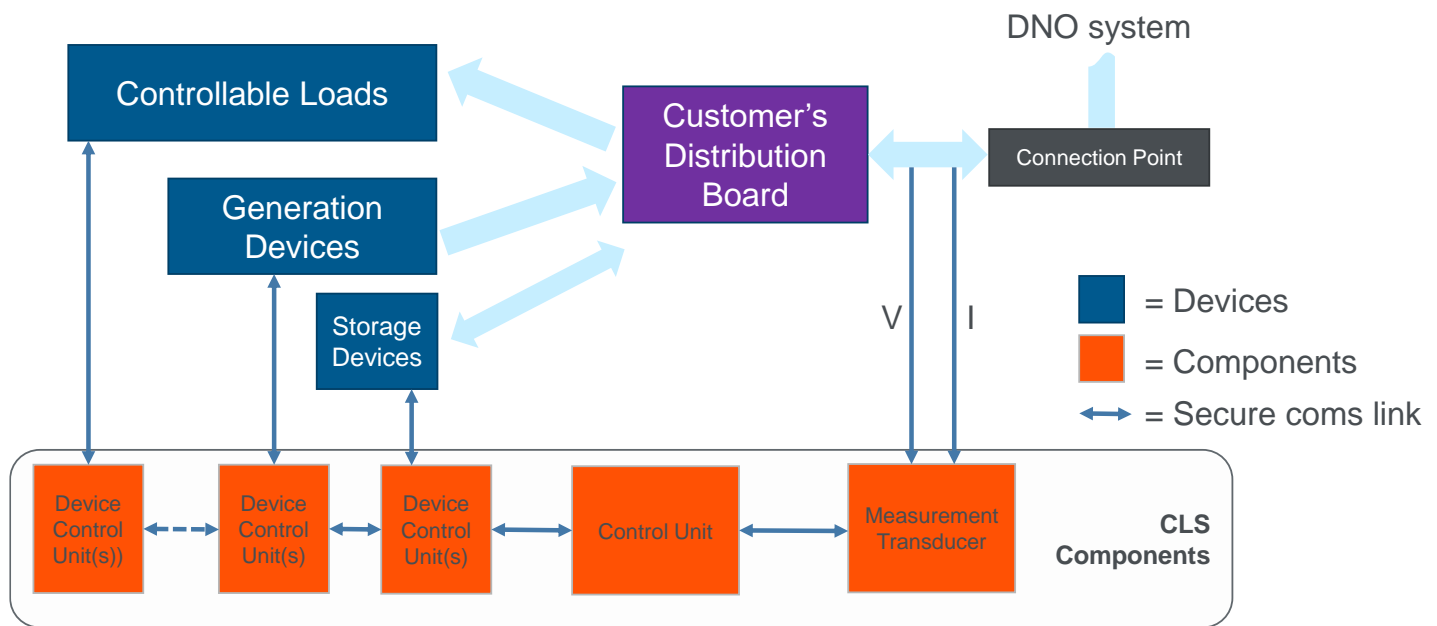

4.2 General CLS Features

The maximum permissible tolerance for the **CLS**'s measurement and control of current is $\pm 2\%$ of the greater of the **MEL** or the **MIL** at the **Connection Point**. These tolerances shall, as far as possible, take account of sensing and/or measurement errors, processing errors, communication errors and control errors. Consideration shall also be given to environmental factors (eg the expected ambient temperature range). For example, where the **MEL** is zero and **MIL** is 400A the maximum acceptable tolerance for the measurement and control of current is $\pm 2\%$ of 400A = $\pm 8A$.

A description of the **CLS**, its controls and settings, and a schematic diagram of the **CLS** must be supplied to the **Customer**. Where the **CLS** is controlling export, an operation diagram as required by EREC G59, G83, G98 or G99 as appropriate shall be permanently displayed at the **Customer**'s site. The schematic diagram can be of a form similar to Figure 4-1, and include sufficient detail so that the interaction of the **Devices** and **Components** can be understood.

Note that the voltage measurement is shown in Figure 4-1 as being at the **Connection Point**. In general it will be admissible if voltage sensing is done elsewhere in the **Customer**'s **Installation** that is appropriately representative of angle of the voltage at the **Connection Point**.

The settings and controls of the **CLS** will not be generally accessible to **Customers**. The **Manufacturer** or **Installer** shall consider how settings can be applied by, and access limited to, **Manufacturers** or **Installers** via password, PIN or physical access capable of being sealed. These arrangements shall be stated in the description of the **CLS** referred to in this section.

4.3 Operational States

A **CLS** has four key operating states:

4.3.1 State 1- Normal Operation

This is the normal operating state of the **CLS**. In this state the **CLS** will be modulating the consumption and generation of the **Devices** it controls such that current flowing at the **Connection Point** remains within that required by the **MEL** or **MIL** as appropriate and that the voltage at the **Connection Point** remains within statutory limits⁶. The **CLS** might be modulating the consumption and generation of the **Devices** continually in real time. Alternatively, if the behaviour of the **Devices** is balanced, or controlled by other systems, such that the current flow at the **Connection Point** is normally within the **MEL** or **MIL**, then only by exception should the balance be disturbed sufficiently such that the current flow at the **Connection Point** encroaches on the **MEL** or **MIL**. In this latter case the **CLS** will then need to actively modulate the consumption and generation of the **Devices**.

Figure 0-1 illustrates this.

It is also possible that **Customers** might have their **Devices** controlled by other systems than the EREC G100 **CLS**, eg in response to market or other signals. However, in this case, the **CLS** must be able to override any such system to ensure that the current flowing at the **Connection Point** remains within the state 1 limits.

4.3.2 State 2 – Occasional Excursion

From time to time conditions within the **Customer's Installation** could be such that the current flow exceeds the **MEL** or **MIL**. This could be caused by normal operation (eg switching) of the **Customer's Devices** or other loads in the **Customer's Installation** (eg a kettle in a **Domestic Installation**), or it could be caused by the sudden failure or tripping of part of the **Customer's** load or generation equipment. Very short excursions into state 2 as part of normal operation are not problematic provided they are short, ie less than 15s. However longer excursions, such as might accompany failure or tripping of a **Device** should be rare by definition, and therefore not considered as normal operation. In both cases the **CLS** will recognize the condition and shall have the capability to control the **Devices** and bring the current flowing at the **Connection Point** back within the **MEL** or **MIL** and within a maximum response time.

The default maximum response time for a **CLS** to bring the current flow back within **MEL** or **MIL** is 1 minute. For industrial or commercial installations where slow acting **Devices** (such as reciprocating gas engine driven generation, micro hydro etc) are controlled, a default maximum response time of 3 minutes will apply unless the **DNO** identifies that state 2 operation will result in network voltages above the statutory maximum. In these cases the

⁶ Note for **Customer Installations** where the voltage at the **Connection Point** is at **HV** the **DNO** will agree any voltage limits on a per site basis with the **Customer**.

DNO may require the response time to be 1 minute. There is more detail on this condition in section 4.4 below.

As state 2 is designed to cater for rare events, the number of occasions that a **CLS** can operate in state 2 for more than 15s is limited. This is covered in more detail in section 4.5.

4.3.3 State 3 – Failed State

This state is designed to cater for a failure of the **CLS** in some way. In this state the **Devices** shall be set to operate at levels that cannot, whatever happens next to equipment in the **Customer's Installation**, breach the **MEL** or **MIL**. In many cases this will simply mean that the **Devices** are tripped or switched off. An alternative could be that some **Devices** are set to a clearly defined low power state such that their operation can never result in the current flowing at the **Connection Point** approach the **MEL** or **MIL**.

If state 3 operation is caused by:

- excessive import then the generation **Devices** shall not be constrained or tripped by the **CLS**;
- excessive export then load **Devices** shall not be constrained or tripped by the **CLS**.

The failure mechanisms, consequences and responses are covered in section 4.5 below.

When a failure is detected by the **CLS**, it shall set all the **Devices** into their state 3 operational state within 15s.

4.3.4 State 4 – Operation without CLS

State 4 need not be implemented by default. It is a state that allows operation of some of the **Customer's Devices** without the control of a **CLS**. Such a state might be required if the **CLS** is out of service for a considerable time for some reason.

The operational arrangements for state 4 in many cases will be the same as those for state 3, ie with the **Devices** switched off or set to a permanently clearly defined low power state. However, particularly for larger industrial or commercial installations, the **DNO** might specifically agree how the installation can be operated in the absence of a functioning **CLS**. State 4 operation will only be allowed by pre-agreement with the **DNO**.

4.4 Design Limits

The limitation on the capacities of **Customer's Devices** is set by state 2 operation. In state 2 operation, the **MEL** or **MIL** is breached and the resultant high current flows can lead to a number of undesirable or even dangerous situations. In general temporary high currents can be tolerated provided there are appropriate caps on their magnitude and duration, and on consequential effects such as voltage rises or dips.

State 2 operation shall take account of the likely worst case situation that might arise, taking into account common mode failures and effects that may affect **Devices**. By way of an example if there are several significant separately controlled loads that are normally balancing the energy production from generation on site, the **CLS** will need to allow for the worst case in terms of those loads being switched off or tripped. If these loads are truly independent and no common mode failure, then the worst case will be the largest of these being switched off. However if there is a common mode failure, such as the loads all being

supplied from the same distribution board or have a common cable between them and the generation, then the worst case is simultaneous loss of all of them.

For **Domestic Installations**, the effect of the **Customer's** loads on the current flow at the **Connection Point** can be significant, either because they are very small compared to the generation, or where they are significant they could be subject to sudden cessation or tripping. Therefore, for simplicity the default approach for all cases shall be to ensure that the aggregated **Current Rating** of all generation **Devices** is less than the limit of state 2 operation.

The **DNO** will assess the **Customers' Devices** and the proposed **CLS** in terms of their effect on:

- The thermal limits of the **DNO's Distribution Network**;
- The voltages at the **Customer's Connection Point** and the **Connection Point** of other **Customers** in the vicinity; and
- The **DNO's** protection.

The **DNO** will assess the **Customers' Devices** and **CLS** proposal based on these criteria and the maximum **Current Ratings** of the **Customer's Devices** shall be limited so that none of the criteria set out in the following sections are breached.

Any overload protection used for any **Device** in compliance with this EREC G100 must be arranged to grade with, and match the characteristics of, the **DNO's** protection at the **Connection Point**. The maximum operating time of such protection must not exceed 10s.

As above where the relevant electrical protection of the **Device** has been arranged to fully grade with the **DNO's** protection, the capacities of **Customers' Devices** will be taken to be their nominal or practical rating. For example a group of 10 11kW single phase electric vehicle chargers operating as a single load controlled by a single controller (ie a controller for that purpose, not one that is specifically designed to meet the requirements of this EREC G100) that limits their overall instantaneous demand to 30kW (single phase), ie to allow for charging diversity, and is protected by a single 140A single phase MCB (for example) that can be demonstrated to grade with the **DNO's** protection, shall be considered to be a 30kW device. Where the **DNO's** protection is provided by fuses the protection of the **Customers Device** (the MCB in this example) should be arranged to match this appropriately; eg an inverse characteristic.

4.4.1 Thermal Limits

The highest currents that can be imposed on the **DNO's Distribution Network** will be assessed and the **DNO** will confirm that these currents are tolerable on the **DNO's Distribution Network** for up to 5 minutes. Note that this is the design approach. The actual time that the **CLS** can allow state 2 operation to persist is only 1 minute (or 3 minutes where specifically notified to the **DNO** for appropriate technology such as reciprocating gas engine driven generation, micro hydro etc and where there is no adverse voltage effect as explained in section 4.3.2).

In state 1 operation, if there is a risk that operating at the **MEL** or **MIL** causes frequent inadvertent excursion from state 1 operation into state 2 operation it will be appropriate to set a state 1 operating limit that is sufficiently within the **MEL** or **MIL** limits, in order to minimise the frequency or duration of state 2 operation to avoid triggering the **CLS** functionality set out in 4.5.2.1.

4.4.2 Voltage Limits

4.4.2.1 State 2 Operating Limits

DNOs have to respect the statutory limits on voltages as defined in the Electricity Safety Quality and Continuity Regulations (2002, SI 2002 2665). Circumstances, such as faults on **Customers' Installations**, or on the **DNO's Distribution Network** may cause temporary excursions outside these limits. These exceptions are expected occasionally, but must be limited. BS EN 50160 sets the expected worst case for excursions and any voltage excursion caused by state 2 operation shall fall within this envelope in BS EN 50160. Recognizing this limit, small excursions above or below the statutory limits should be limited to no more than 1 minute.

DNOs will assess the worst case state 2 operation effect on the voltage of the **Distribution Network**. The **Customer's Devices** will be limited in capacity such that:

- the worst case highest voltage cannot exceed 112% of nominal voltage (ie 257.6V at a nominal voltage of 230V) where the **Customer's Connection Point** is at **LV** or 108% of nominal voltage where the **Customer's Connection Point** is at **HV**; and
- the worst case lowest voltage cannot be less than 87% of nominal (ie 200.1V) where the **Customer's Connection Point** is at **LV** and 92% of nominal voltage where the **Customer's Connection Point** is at **HV**.

In addition, **DNOs** will consider the step voltage changes associated with transitions between state 1 and state 2 operation that will be imposed on the **Distribution Network** (and hence on other **Customers**) in accordance with EREC P28.

Optionally, a **Manufacturer** or **Installer** may include, by agreement with the **DNO**, a voltage controlled response such that in those cases where the voltage at the **Connection Point** is likely to breach statutory limits the **CLS** instructs corrective action as an alternative to moving into state 2 operation (and hence risking triggering the state 3 **Fail Safe** condition – see section 4.5.1.2).

4.4.3 Protection Limits

For installations where the **DNO's** interface or upstream protection is provided by fuses state 2 operation shall not impose a greater current flow than 145% of the nominal fuse rating.

Where the **DNO's** interface or upstream protection is provided by relays, the **DNO** will assess the maximum current flow based on the appropriate settings for these relays.

4.5 Fail Safe

All **CLSs** must fail to safety. If it is not inherently possible to arrange this within the **CLS**, alternative safety measures shall be provided as described in section 4.5.3.

For all **High Voltage** connected installations overload and/or reverse power protection (as described in section 4.5.3) shall be installed to disconnect the installation (or relevant **Devices** by agreement) in the event that the **CLS** fails to appropriately manage export or import. It shall be the responsibility of the **Customer** to specify and satisfy the **DNO** that the protection meets this requirement.

4.5.1 Failure Detection

Should a **CLS** fail, for any reason, there is the possibility that unsupportable high currents will flow, giving rise to the risk of damage to equipment or interference with other **Customers'** equipment and/or that excessively high or low voltages are present on the **Distribution Network** for unacceptable periods of time.

Failure detection shall include internal failure of the **CLS** and its **Components**, as well as the failure of any communication channels used by the **CLS** to communicate between its **Components** and between **Components** and **Devices** as described in this section.

Note that failure of the power supply to the **CLS**, or to the **Customer's Installation** or the zero voltage conditions associated with the controlled starting or stopping of the **CLS**, shall not be classed or detected as a low voltage condition triggering state 3 operation.

4.5.1.1 Internal Failure

The **CLS** shall detect any internal failure and move its operation into state 3 immediately (ie within 15s) after detecting such a failure. The **CLS Manufacturer** or **Installer** shall state how:

- the **CLS** will detect internal failures;
- the **Manufacturer** or **Installer** has assessed that this is the complete range of possible failures; and
- this can be demonstrated in testing.

4.5.1.2 Communication failures

The **CLS** shall detect any defect in communication between its **Components and Devices**. This is especially necessary where the **CLS** is comprised of dispersed **Components**, including any **Components** that are transducers fitted at the **Connection Point** to measure current flows and direction. In particular the **CLS** shall detect discontinuity of the secondary circuit or the magnetic circuit of any current transformers employed.

Any communication failure shall trigger a move into state 3 immediately (ie within 15s) after detecting such a failure.

Notwithstanding this, for communication between **Components** and between **Components** and **Devices** relying on non-hard-wired paths, short drop-outs of communication of up to 15s are permissible before triggering state 3 operation.

Where, in response to a loss of communication to a **Device**, that **Device** immediately ceases operation (ie no current flows into or out of it), the **CLS** may remain in state 1 operation without registering a transition into state 3. All other provision of this EREC G100 shall apply to the operation of the **CLS** whilst communication to that **Device** is unavailable. When communication to that **Device** is restored the **Device** shall restart in a controlled manner so there is minimal risk of an excursion into state 2 operation.

For **Components** and **Devices** which are both hard wired and close coupled (for example where a **Component** is integrated into a **Device**, is located immediately adjacent to it and there is essentially only internal wiring between the two) the need for detecting communication failures can be waived provided the **Manufacturer** or **Installer** can demonstrate that this is reasonable.

Note that the **CLS** shall treat the failure of a **Component's** or **Device's** power supply as a communication failure. Note that **Devices** may or may not have discrete separately connected power supplies from the main current carrying connections.

4.5.1.3 Excessive State 2 Operation

Although state 2 operation is expected, operation for periods exceeding 15s is not expected to be frequent. Accordingly if a **CLS** breaches any of the following criteria, it shall enter state 3 operation immediately (ie within 15s):

- A single excursion into state 2 operation that persists for more than 1 minute (or 3 minutes as allowed in 4.3.2);
- There are more than three excursions (each of more than 15s and less than 1 minute (or 3 minutes as allowed in 4.3.2)) into state 2 operation in any 24 hour period;
- The time between any two consecutive excursions into state 2 operation of greater than 15s is 10 minutes or less (measured from the time of re-entry into state 1 operation from state 2 operation following the first excursion).; or
- For installations where the maximum excursion period is 3 minutes (as allowed in 4.3.2) the total time in state 2 operation in any 24 hour period, but neglecting any excursion of 15s or less, exceeds 8 minutes.

Excursions that do or do not count towards excessive state 2 operation are shown diagrammatically in Figure 4-2.

The implementation of the necessary counters and timers in the **CLS** must be done in non-volatile memory so that they are not reset if power to the **CLS** is lost.

Figure 4-2 – Excursions into State 2 counting towards the excursion limit

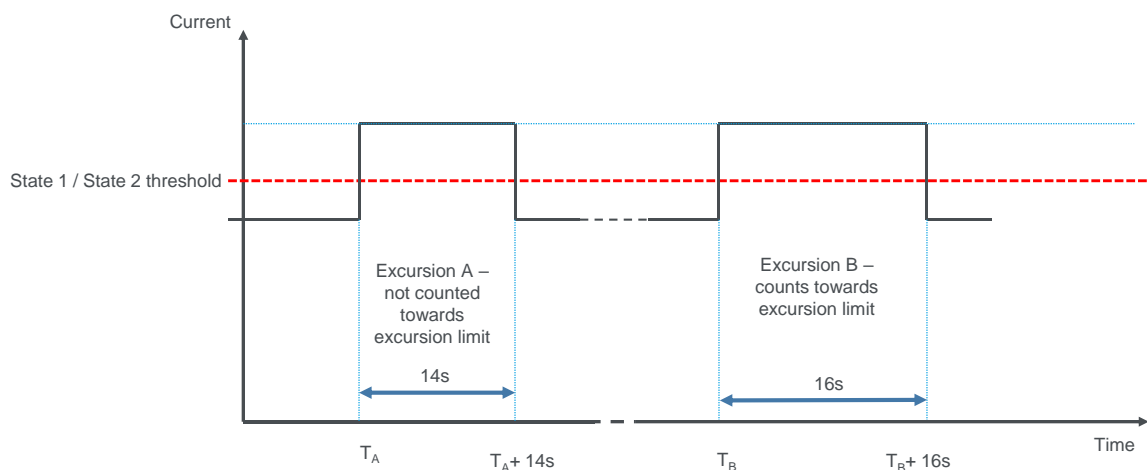

4.5.2 Recovery from Failure

The **CLS** should be capable of interrogation by the **Customer** to determine the nature of the failure.

The **Manufacturer** or **Installer** shall ensure that the **CLS** remains in state 3, including through the power supply to the **CLS** being cycled on/off, until it is reset. In most cases this will be by the **Customer**, via a **Manufacturer** or **Installer** provided facility, but subject to the additional requirements of this section.

Manufacturers or **Installers** may wish to provide a test facility so that testing whilst commissioning will not lead to multiple state 2 excursions triggering lock-out in state 3 (see 4.5.2.1). It must not be possible to leave the **CLS** operating in the test mode. **Manufacturers** or **Installers** shall explain how such a facility works and the risk of inappropriate use is controlled.

4.5.2.1 Internal Failures and Excessive State 2 Operation

For internal failures, and excessive state 2 operation, the **Customer**, following resolution of the cause of the failure, shall be able to reset the **CLS** back to normal operation as follows:

- For **CLSs** installed in **Domestic Installations**, 3 resets shall be allowed in any 30 day period. If this criterion is breached the **CLS** will remain locked in state 3 pending further investigation and resolution of the issues causing the **CLS** to be locked-out in state 3. The **Manufacturer** or **Installer** shall propose how lock out in state 3 can be resolved.
- For **CLSs** installed in non-domestic installations any excursion into state 3 operation shall not be capable of being reset within 4 hours of the start of state 3 operation.
- In both cases the **Manufacturer** or **Installer** has the option of performing a reset over the internet or by other remote means. Where such a remote reset facility is implemented, it must rely on direct communication between the **Customer** and the party implementing the reset to ensure that the reason for the lockout is understood and addressed.

Note that there is no limit to the number of resets that are allowed for state 3 operation arising from communication failures, as required by 4.5.1.2 and 4.5.2.2.

4.5.2.2 Communication Failures

The **Customer** shall be able to reset the **CLS** back to normal operation immediately in every case when communication has been restored, ie the lockout feature of 4.5.1.3 does not apply. A **CLS** may be arranged by the **Manufacturer** or **Installer** to self-reset from state 3 when state 3 operation is caused solely by communication failures.

4.5.3 Overload Protection and Alternatives to Fail Safe

For **Customer's Installations** connected at **HV** overload and/or reverse power protection shall always be fitted. For **Customers Installations** connected at **LV**, if the **Manufacturer** or **Installer** does not provide a **Fail Safe CLS**, and/or the **Customer** cannot prove **Fail Safe** functionality then a **CLS** can still be used, but the **Customer** will need to install appropriate protection at the **Connection Point**.

Suitable protection shall include overload protection (which might also need to be directional to cater for import and export limits) or reverse power protection.

Note that fuses, especially the **DNO's** fuses, offer limited overload protection capabilities. Fuses generally are designed to be effective for short circuit faults rather than overloads. For overload protection it will not generally be appropriate for designs to use fuses; overload (or reverse power) protection shall be designed to use appropriate relays that match the characteristics of the **DNO's** protection at the **Connection Point**. Overload protection arrangements are therefore unlikely to be suitable for **Domestic Installations**.

The design and settings of the protection shall be agreed with the **DNO** and recorded in the **Connection Agreement**.

4.5.3.1 Overload or reverse power backing up a CLS

For all **HV** installations, and installations at **LV** where a non **Fail Safe CLS** is installed, the **Customer** shall install overload, or reverse power, protection at the **Connection Point**. Overload protection shall be set no higher than the state 2 limits, import or export or both as appropriate. The protection shall be instantaneous (ie fast acting with no definite-time delay.)

4.5.3.2 Overload or reverse power as an alternative to a CLS

For overload protection used as an alternative to installing a **CLS**, the **Customer** can install overload protection at the **Connection Point**. In these cases it should be set at the **MEL** or **MIL** or both as appropriate, with a default operating margin of 2%. Where overload protection is installed on individual **Devices**, as opposed to the whole of the **Customer's Installation** at the **Connection Point**, no margin shall be added to the **Device's** rating, ie the setting shall be the same as, or less than, the **Device** rating. The characteristic of the protection shall be arranged to match that of the **DNO's** protection at the **Connection Point** and the maximum allowable operating time is 10s.

Where reverse power protection is appropriate it will generally be fitted at the **Connection Point** and can be arranged to trip either the relevant generation or the whole of the **Customer's Installation**, as agreed between the **DNO** and the **Customer**.

4.6 Communications

The **Manufacturer** or **Installer** must select an appropriate and secure communication medium for communication between the **Components** forming the **CLS**, and the **Devices** controlled by the **CLS**, noting that communication failures will cause state 3 operation of the **CLS**.

The **Manufacturer** or **Installer** shall provide information describing the communication media used in the **CLS** with supporting information as to why this is appropriate in terms of reliability and security.

4.7 Cyber security

Recognizing that cyber security is an evolving area, the **Manufacturer** or **Installer** shall consider the cyber security risks posed for the **CLS** both in terms of the communication between the **Components** forming the **CLS**, and the **Devices** controlled by the **CLS** and also in terms of interaction with any other system, including any **Manufacturer's** product management systems.

Accordingly this EREC G100 makes no specific cyber security compliance requirements. However the **Manufacturer** or **Installer** shall provide information describing the high level

cyber security approach, as well as the specific cyber security requirements complied with. The statement will make appropriate reference to the **CLS**'s compliance with any relevant aspects of:

- ETSI EN 303 645 CYBER; Cyber Security for Consumer Internet of Things: Baseline Requirements;
- Distributed Energy Resources – Cyber Security Connection Guidance - published by BEIS and the ENA;
- PAS 1879 Energy smart appliances – Demand side response operation – Code of practice; and
- Any other relevant standard that has been incorporated in the design of the **CLS**.

4.8 Access to DNOs' Current and Voltage Signals

In general **Customers** will not have access to the **DNO**'s current transformers, and where the **Connection Point** is at **LV Customers** will generally be able to provide appropriate voltage signals themselves.

For the purposes of this EREC G100 Rogowski coils are an acceptable substitute for conventional current transformers.

The provisions of Distribution Code DPC6.7.8 shall apply for access to current and voltage signals from the **Connection Point**.

For voltage signals where the **Connection Point** is at **HV**, since the voltage signal is used for determining the direction of power flow, and for measuring the **Connection Point** voltage, it might be possible to use an **LV** supply within the **Customer's Installation** provided the phase angle between the measured voltage and that at the **Connection Point** remains fairly constant (eg where it is derived from a lightly loaded transformer electrically close to the **Connection Point**).

4.9 Generation in Non-exporting Sites

Where a **Customer** wishes to install generation but has no need to export power from the **Customers Installation**, an alternative to deploying a **CLS** is for the **Customer** to install reverse power protection at the **Connection Point**.

The reverse power protection can be arranged to control or trip the generation or to trip the whole of the **Customer's Installation**. The design of the reverse power protection, and its settings, shall be agreed with the **DNO** and recorded in the **Connection Agreement**.

4.10 Multiple CLSs in a Single Installation

In some installations **Customers** might want to install more than one **CLS** controlling separate sets of **Devices**. For **Customer's Installations** connected at **LV** the sum of all the **Current Ratings** of generation and storage (in export mode) **Devices**, and/or the sum of all the capacities of significant loads and storage (in import mode) **Devices** shall be less than the respective state 2 limits for that installation. Ideally one **CLS** should be configured to act as the master **CLS**, and all other **CLSs** configured to harmonize with it, but this is not an essential requirement. Multiple independent **CLSs** are not prohibited provided compliance with this EREC G100 by the **Customer's Installation** is not compromised. **Customers** should note that multiple **CLSs** will need carefully setting up to avoid hunting, instability or other forms of undesirable interactions between them.

For **Customer's installations** connected at **HV**, if it is not possible for a **CLS** to be confirmed as a master for the installation, suitable overload protection, directional if necessary, shall be fitted at the **Connection Point** and arranged to trip either the whole site, or appropriate **Devices**, within 1 minute (or 3 minutes for appropriate technologies and no other limitation on voltage rise – see 4.3.2) to ensure a **Fail Safe** arrangement as described in 4.5.3. The **Customer** will agree with the **DNO** the exact arrangements and record the design approach in the **Connection Agreement**.

4.11 Domestic Installations

The principles and requirements of this EREC G100 shall apply in full to **Domestic Installations**. It is expected that generally **Domestic Installations** will comprise **Fully Type Tested CLSs**.

Where a **CLS** is designed to manage export to the **DNOs Distribution Network** and is **Fully Type Tested** it shall be capable of having the state 1 operating limit (ie the **MEL**) set to 16A, 32A, 60A, 80A or 100A (per phase values). **Manufacturers** can provide other settings, but not more than 100A, and shall ensure the design minimises the risk of **Installers** inadvertently selecting an inappropriate limit. The **Installer** shall make the appropriate selection for the specific installation, and which shall be protected from being changed in accordance with the requirements of section 4.2. The **DNO** would not expect to witness the installation, commissioning and operation of the **CLS**.

Where a **CLS** is designed to manage import from the **DNOs Distribution Network** and is **Fully Type Tested** it shall be capable of having the state 1 operating limit (ie the **MIL**) set to 60A, 80A or 100A (per phase values). **Manufacturers** can provide other settings, but not more than 100A and shall ensure the design minimises the risk of **Installers** inadvertently selecting an inappropriate limit. The **Installer** shall make the appropriate selection for the specific installation, and which shall be protected from being changed in accordance with the requirements of section 4.2. The **DNO** would not expect to witness the installation, commissioning and operation of the **CLS**.

These principles would also apply where a **Fully Type Tested CLS** is designed to manage both export to and import from the **DNOs Distribution Network**.

For commissioning **Fully Type Tested CLSs** the requirements of 5.2 apply.

4.12 Interfaces with DNOs' Systems

By agreement it may be appropriate to interface a **Customer's CLS** with systems used by a **DNO** to manage their network dynamically. This might be to implement active network management, a flexible connection or a flexibility contract between the **Customer** and the **DNO**.

The interface could be to accept a single new set point for the maximum current that can be exchanged at the **Connection Point**, or a variable set point. In either case the **DNO** will provide the protocols and other information necessary for the interface.

5 Application and Acceptance

Customers (or **Installers** on the **Customers'** behalf) shall provide information on the proposed **CLS** and **Devices** to enable **DNOs** to make an assessment of the risk to the **Distribution Network**.

The following information shall be provided with the **CLS** application (in addition to information required for any **Device** that is intended to be controlled by the **CLS**):

- Completed **CLS** application (Form A – appendix A);
- Schematic diagram of the **CLS** and associated **Devices**;
- Where the **CLS** has not been **Fully Type Tested**, the **Manufacturer's** G100 Product Declaration (Form B - Appendix B) – including:
 - Explanation of the **CLS** operation;
 - Description of the **Fail Safe** functionality, commissioning and demonstration of compliance.

If necessary this can be submitted in stages if all the information is not available at the time of application.

5.1 General

The **Customer** (or the **Installer** on the **Customer's** behalf) is responsible for demonstrating that any **CLS** installed in the **Customer's Installation** complies with the requirements detailed in this document.

Installers are responsible for demonstrating, via **Manufacturers'** type tests, other published information, and/or appropriate site tests that the **CLS** complies with the requirements detailed in this document. **Installers** are also responsible for providing **Customers** who own that equipment with sufficient information to enable **Customers** to meet their own obligations to demonstrate compliance.

In order to safely and effectively test a **CLS**, it is necessary to be able to simulate instances where the **CLS** is expected to operate. Where a **CLS** is integrated into the **Device** it controls, has a range of settings, and is intended to be a **Fully Type Tested CLS**, then it shall be tested at the extremities of its export and import current settings, and one intermediate export or import current setting. This requirement does not apply to stand alone **CLSs** that are commissioned on site.

5.2 Site commissioning of Fully Type Tested CLSs

Where the functions described in section 5.6 have been validated in a type test by the **Manufacturer** (ie the **CLS** is **Fully Type Tested**), a reduced set of tests can be undertaken on site.

In these cases it will be sufficient to undertake the communication and power supply **Fail Safe** tests in section 5.5 (ie all the tests in Table 5-1 - Test Sequence) to prove that the **CLS** reacts appropriately.

Form C (Appendix C) must be submitted in all cases, but Form B (Appendix B) is not required where the reference to the **Fully Type Tested** compliance information on the ENA's Type Test Register is included as a reference on Form C.

5.3 Commissioning Sequence

CLS commissioning shall only be undertaken after all other **Device** commissioning has been successfully completed.

The **Customer** (or the **Installer** on the **Customer's** behalf) shall provide to the **DNO** all relevant scheme drawings and information to enable safe, informed commissioning of the **CLS**.

In order to ensure that commissioning does not cause any safety issues on the **DNO's Distribution Network**, the following commissioning sequence shall be followed. Tests shall be performed in the sequence indicated and the process shall only proceed to the next stage once the preceding stage has been successfully undertaken:

The commissioning test actions shall be carried out in the following order:

1. Implement the measures to ensure that the **MEL** or **MIL** cannot be exceeded.
2. Perform **Fail Safe** tests.
3. Perform operational testing.
4. Set export and/or import limits.
5. Verify export and import limits are correct.

5.4 Preventing the Limits Being Exceeded During Testing and Commissioning

Care shall be taken whilst testing and commissioning the **CLS** so that the **MEL** or **MIL** is not breached. This may involve setting the export or import limit to a lower threshold for compliance demonstration purposes. A combination of the following measures should be considered to ensure that **MEL** and/or **MIL** is not exceeded during setup/testing:

- Temporarily programming the **CLS** export and/or import or setpoint limits to 50% (or less) than **MEL** and/or **MIL**;
- Temporarily narrowing the range of the **CLS** voltage limits (ie bringing the set points closer to the nominal voltage);
- Restricting the maximum output of the generation (eg on a PV system with multiple inverters, turning off a number of the inverters);
- Restricting the amount of load that is connected; and
- Operating a temporary load, load bank or generator.

If the **CLS** settings need to be changed in order to demonstrate operation, then they shall be restored and confirmed once testing is complete.

Note that testing will lead to what normally would be considered excessive state 2 operation and hence lock-out. **Manufacturers** or **Installers** may provide a test mode to allow for this – see 4.5.2.

5.5 Fail Safe Tests

The purpose of the **Fail Safe** tests is to ensure that should any part of the **CLS** fail, the current flow across the **Connection Point**, and the voltage imposed on the **Distribution Network**, will remain within, or return within the required time to, the design limits.

There are a number of potential options for reducing the current flows such that the design limits are not breached including:

1. Switching off relevant **Devices** completely;
2. Reducing the number of the **Devices** operating such that the aggregate current capacity of the **Devices** remaining operational is equal or less than the **MEL** and / or **MIL**; and
3. Operating all **Devices** at a restricted output such that as in aggregate their combined current is safely and securely limited to be equal or less than the **MEL** and/or **MIL**.

The **Fail Safe** test process comprises a sequence of tests on each separate **Component** of the **CLS**. Each **Component** and **Device** needs to have, where relevant, its communication medium removed or interrupted and, separately, its power supply interrupted.

At no time during the **Fail-Safe** test sequence shall the current flowing through the **Connection Point** rise above the programmed export and/or import limit (taking account of **Manufacturer's** published tolerances) for a period of time longer than the specified reaction time.

NOTE: The power supplies for some **Components** may take a short while to power down (due to power stored in capacitors). This will cause a slight delay in the response time of the system. In such cases the reaction time is measured from the point at which the **Component** powers down, not the point at which the power supply is disconnected.

The following table describes a typical test sequence. Not all **CLSs** will have all of the **Components** listed and others may have additional **Components** that need to be included in the test sequence. The **CLS** shall be restored to normal operation after each of the tests below.

Table 5-1 - Test Sequence

No.	Component	Test
1	Connection Point Component (ie transducer)	Remove power supply to transducer†
2	Principle CLS Component(s)	Remove power supply
3	Components controlling generation Devices	Remove power supply to each in turn
4	Components controlling storage Devices	Remove power supply to each in turn
5	Components controlling load Devices	Remove power supply to each in turn
6	Communication controller and or hubs/switches etc	Remove power supply to each in turn
7	Communication between Components	Remove/interrupt communication to each Component in turn†

8	Where applicable communication between Components and Devices	Remove/interrupt communication between each Component and associated Device in turn
9	CLS system	With reference to the Manufacturer's published information on internal failures (see 4.5.1.1) undertake the recommended tests etc to confirm that the CLS detects and reacts appropriately to internal failures.

†There are safety issues in interrupting current transformer circuits, which can give rise to dangerously high voltages. Care must be taken to ensure that the current transformer connections and/or secondary circuits are either tested with zero primary current, or are short circuited, or ideally both, before the circuit to the transducer is opened.

For each test confirm that the **CLS** enters state 3 operation, and that on restoration of communication or power to the relevant **Component** or **Device** it is then possible to immediately reset the **CLS** into state 1 operation.

5.6 Operational tests

In order to safely and effectively test a **CLS**, it is necessary to simulate normal state 1 operation and then the transition from state 1 to state 2 to confirm that it responds appropriately. Note that operating setpoints must be reduced so that state 2 operation for testing purposes does not exceed the **MEL** or **MIL** as explained in section 5.4. Two different means may be employed to simulate this:

1. Manual control over the **Devices** operating on the site; or
2. Injection testing using a calibrated test set

The method adopted will depend on the nature of the site. On larger sites (eg an office, factory or school with multiple distributed **Devices**), injection testing may be the only practical option.

Note that the tests described in 5.6.1 and 5.6.2 amalgamate the **CLS's** control capability (ie regulating output/input levels of **Devices**) with the correct operation in states 1, 2 and 3. Depending on the design of the **CLS**, and its facilities for testing, it might be necessary to devise a test plan that tests these two aspects (ie control of **Devices** and correct movement between states) separately.

The correct orientation of any part of a **Component** that measures current and/or voltage shall be confirmed.

Operational testing shall be performed that demonstrates satisfactory transition between state 1 operation and state 2 operation. Tests shall be undertaken that demonstrate the correct operation in returning to state 1 operation from state 2 operation as well as showing that excessive state 2 operation will lead to state 3 operation (**Fail Safe**). This is shown conceptually in

Figure 5-1 Test A demonstrates that an excursion outside the test level threshold triggers the correct **CLS** response without triggering **Fail Safe**, whereas test B should trigger the **Fail Safe** condition.

Figure 5-1 shows the tests to be undertaken. Note that the time in brackets is for those technologies (see 4.4.1) where the three minute limit on excess current flow in state 2 applies.

Figure 5-1 – Current Step Tests

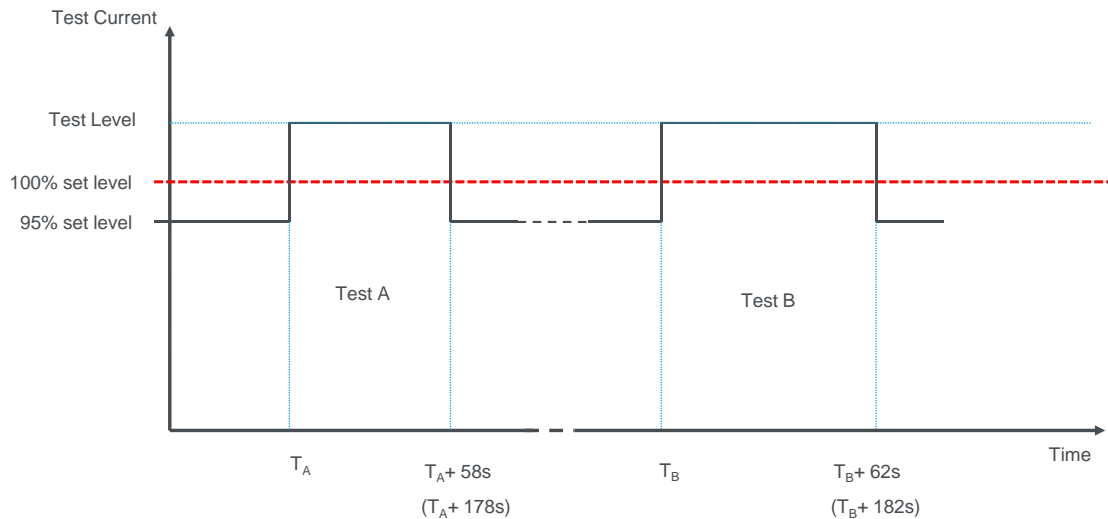

To carry out the tests the site conditions should be adjusted and a generic test method could be:

1. The export and import current limits are adjusted (ie set to zero or a percentage of the **MEL** or **MIL** value).
2. The consumption and/or output of the **Devices** are manually increased / decreased.

Note that if testing without a **Manufacturer's** or **Installer's** test mode, operation in state 2 will lead to lockout in state 3. This is not an issue for a **Fully Type Tested CLS**, but for an installation where the full EREC G100 tests are carried out on site, arrangements will need to be made to cater for this aspect.

Pass-Fail criteria: The **CLS** is considered to have passed the test if during the test sequence the current exported from or imported to the site at the **Connection Point** do not breach the set-point limits for a period of time longer than the specified reaction time.

5.6.1 Operational testing – Manual Load Control

The consumption and/or output of the **Devices** should be manually adjusted to achieve the test levels at the **Connection Point**. Arrangements will have to be made to hold the required test conditions at the **Connection Point** for sufficient time to demonstrate compliance noting that the natural behaviour of the **CLS** will be to resolve (ie reduce) the conditions, ie to move back from state 2 operation into state 1 operation. As described above it might be necessary to take other measures during testing to ensure that the correct fail safe behaviour occurs when the conditions at the **Connection Point** are maintained for longer than the fail-safe time threshold.

5.6.2 Operational testing – Injection Testing

Export and/or import limit conditions can be simulated by temporarily injecting current into the transducer(s) using a calibrated injection test set.

When using an injection test set, there is normally no feedback loop between the **CLS** and the injection test set. This has two significant implications for the test process:

1. As soon as the **CLS** begins to operate, because it sees no corresponding decrease in current flow, the control loop will keep running until the relevant **Devices** reach the limit of their operating range; and
2. To ensure that the **CLS** is reacting by an appropriate amount and within an acceptable time period, a step change needs to be applied by the test set to the **Connection Point** transducer.

5.6.3 Test Sequence

The following test sequence shall be performed as appropriate to the **Devices** installed (eg if there is no control over import, do not carry out the import tests).

Note that where testing is being done under manual load control, tests 1, 3, 4 and 6 shall be completed from Test A (ie tests 2 and 5 can be omitted).

Table 5-2 – List of Tests

Test A	Parameter stepped to the value shown and held there for 58s (or 178s by agreement with DNO)	Required outcome
1	Export = 105% of programmed limit value	State 1
2	Export = 110% of programmed limit value	“
3	Export = 120% of programmed limit value	“
4	Import = 105% of programmed limit value	“
5	Import = 110% of programmed limit value	“
6	Import = 120% of programmed limit value	“
Test B: repeat test 1 and 4 only of the above	Test Level (step change) final value – maintained for 62s (or 182s by agreement with DNO)	
7	Export = 105% of programmed limit value	State 3
8	Import = 105% of programmed limit value	“

The procedure for performing the test is as follows. The test needs to be repeated for import and export as appropriate. Test A demonstrates normal excursion into state 2 followed by a return to state 1 operation. Test B demonstrates excessive state 2 operation and hence confirms the **Fail Safe** functionality.

5.6.3.1 Test A

- Initially apply an injection of 100% of nominal voltage and inject current to mimic a current flow equivalent to 95% of the limit setting.
- Step up the current to give a current flow equivalent to 105% of the limit (for Test 1), Check that change in level is registered appropriately by the **CLS**. Check that the **CLS** is in state 2.
- Check that the current from generation and exporting storage **Devices** reduces to a value at least 5% below the export limit setting within the specified reaction time. Be aware that as noted in 5.6.2 (1) the **CLS** will continue to drive the output of the **Device** away from its original set point.
- Within 58s reduce the injected current back to 95% of the limit. Check that the **CLS** has returned to state 1.

- Repeat the above for step increases from 95% to 110% of the set limit and from 95% to 120% of the set limit as detailed in Table 5-2.

5.6.3.2 Test B

- Initially apply an injection of 100% of nominal voltage and inject current to mimic a current flow equivalent to of 95% of the limit setting.
- Step up the current to give a current flow equivalent to 105% of the limit (for Test 7), Check that change in level is registered appropriately by the **CLS**. Check that the **CLS** is in state 2.
- After 62s (or 182s where appropriate) check that the **CLS** has moved into state 3; reduce the injected current back to 95% of the limit.
- Confirm that all **Devices** have assumed an operating state (including being tripped off) as required by state 3.
- Confirm that **Devices** remain in state 3 operating mode (or off) until the **CLS** is reset.

5.6.3.3 Confirm Reset from State 3

Confirm that state 3 remains in operation until reset, and that all **Devices** can only be operated (if at all) in their state 3 state.

Confirm that the **CLS** in a **Domestic Installations** can be reset to state 1 immediately and that the **CLS** locks into state 3 on the third occasion. Confirm that the **CLS** in a non-domestic installation can only be reset after 4 hours.

5.6.3.4 Test Completion

When injection testing is complete, the correct orientation of any current monitoring connections (including transducer orientations) which may have removed for the test must be checked and verified as being correct.

If settings have been changed in order to demonstrate operation, they must be restored and confirmed as being correct once testing is complete.

Finally allow the **CLS** to operate under normal conditions and confirm that there is no inappropriate control cycling or hunting.

5.7 Overload and Reverse Power Protection

Where overload protection and/or reverse power protection is used for **Customer's Installations** connected at HV, or as an alternative to installing an EREC G100 compliant CLS, or as an alternative to **Fail Safe** (see 4.5.3 and 4.10) these shall be tested by secondary injection.

6 Ongoing Obligations

The **DNO** shall have the right to request that the **Customer** carry out compliance tests and simulations according to a repeat plan or scheme, and additionally after any failure,

modification or replacement of any equipment that may have an impact on the **CLS's** compliance with the requirements of this EREC G100.

Any repeat tests etc shall be undertaken in accordance with section 5 of this EREC G100.

7 Manufacturers' CLS Product Declarations

Manufacturers of **CLSs** having undertaken the required tests shall complete the EREC G100 Product Declaration as set out in Appendix B. A copy of this declaration shall be provided to the **Customer**. The **Customer** will then provide a copy of the product declaration to the **DNO** as set out in section 5 of this EREC G100.

The **Manufacturer** has the option of registering the Product Declaration on the ENA's Type Test Register. In which case it will be sufficient for the **Customer** to quote the ENA reference number on Form C in lieu of presenting a copy of the Product Declaration.

Appendix A- CLS Application Information

This form is available in a Microsoft Word version from the ENA's website.

G100/2 - Form A – CLS Application Information

This form shall be used by all applicants considering installing a **CLS**. This form shall accompany any associated application for new connection to the **Distribution Network** or for the connection of any associated generation, storage or significant load to the **Customer's Installation**.

To ABC electricity distribution **DNO**
99 West St, Imaginary Town, ZZ99 9AA abcd@wxyz.com

Customer Details:

Customer (name)	
Address	
Post Code	
Contact person (if different from Customer)	
Telephone number	
E-mail address	
MPAN(s)	
Customer signature	

Please provide the following information

Explanation / description of the **CLS** operation including a schematic diagram and a description of the **Fail Safe** functionality, eg the response of the scheme following failure of:

- Any **Component**
- Any **Device**

<ul style="list-style-type: none"> • System internal failure • Communication media 	
ENA Type Test Register system reference for the CLS , if known	
Capacities:	Ampere
Requested Maximum Export Limit	
Requested site Maximum Import Limit	
Aggregate sum of all generation and storage capacities	
Aggregate sum of all generation and storage that will be controlled by the CLS	
Aggregate sum of all loads (including storage) in the installation (ie those both controlled by the CLS and those that are not controlled by the CLS .)	
Aggregate sum of all loads (including storage) that will be controlled by the CLS	

Appendix B – Manufacturer’s CLS Product Information

This form is available in a Microsoft Word version from the ENA’s website.

G100/2 - Form B - Compliance Verification Report for Customer Export or Import Limitation Schemes

This form shall be used by the **Manufacturer** to demonstrate and declare compliance with the requirements of EREC G100. The form can be used in a variety of ways as detailed below:

1. For Fully Type Tested status

The **Manufacturer** can use this form to obtain **Fully Type Tested** status for a **CLS** by registering this completed form with the Energy Networks Association (ENA) Type Test Register.

2. To obtain Type Tested status for a product

The **Manufacturer** can use this form to obtain **Type Tested** status for one or more **Components** which are used in a **CLS** by registering this form with the relevant parts completed with the Energy Networks Association (ENA) Type Test Register.

3. One-off Installation

The **Installer** can use this form to confirm that the **CLS** has been tested to satisfy the requirements of this EREC G100. This form shall be submitted to the **DNO** before commissioning.

A combination of (2) and (3) can be used as required, together with Form C where compliance of the **CLS** is to be demonstrated on site.

Note:

If the **CLS** is **Fully Type Tested** and registered with the Energy Networks Association (ENA) Type Test Register, Form C shall include the **Manufacturer’s** reference number (the Type Test Register system reference), and this form does not need to be submitted.

Where the **CLS** is not registered with the ENA Type Test Register or is not **Fully Type Tested** this form (all or in parts as applicable) shall be completed and provided to the **DNO**, to confirm that the **CLS** has been tested to satisfy all or part of the requirements of this EREC G100.

CLS Designation			
Manufacturer name			
Address			
Tel		Web site	
E:mail			
Installer’s name			
Address			

Tel		Web site	
E:mail			

Export/Import capabilities			
Export	Y / N	Import	Y / N
Description of Operation			
<p>EREC G100 section 4.2 requires a description of the CLS, and schematic diagram, to be provided to the Customer. Please provide that description and the diagram here.</p>			
Communications Media			
<p>Document the provisions made for the use of various communication media, and both the inherent characteristics and the design steps made to ensure security and reliability.</p>			
Cyber Security			
<p>Confirm that the Manufacturer or Installer of the CLS has provided a statement describing how the CLS has been designed to comply with cyber security requirements, as detailed in section 4.7.</p>			
Power Quality Requirements			
<p>Where the CLS includes the power electronics that controls generation or loads (as opposed to the power electronics being included in Devices that are subject to their own power quality compliance requirements) please submit the harmonic and disturbance information here as required by EREC G5 and EREC P28.</p>			

Fail Safe		
<p>CLS internal failure: please submit here the description of the internal Fail Safe design and operation. Please also document how it has been demonstrated, including the non-volatile recording of times and numbers of state 2 operations, and confirm the overall response of the CLS to this internal failure.</p>		
<p>Communication and power supply failures between Components and Devices. Please document here compliance with EREC G100 section 5.5.</p>		
Component/Device number/description	Communication failure test	Power supply failure test

Operational Tests						
<p>In accordance with EREC G100 section 5.6 undertake the tests A and B to confirm correct operation in state 1 and state 2, that transition into state 3 occurs as required, and that behaviour in state 3 is also as required.</p>						
Test A						
Nominal Export Limit (for type tests this will be at maximum, minimum and one intermediate setting) in Amp:						
Nominal Import Limit (for type tests this will be at maximum, minimum and one intermediate setting) in Amp:						
No	Starting level	Step value	CLS registers change in level?	CLS and/or Component and/or Device initiates correct response of ≥ 5%?	Duration of step in test	Correct state 1/ state 2 operation
1						

2						
3						
4						
5						
6						
Test B						
Nominal Export Limit:						
Nominal Import Limit						
No	Starting level	Step value	CLS registers change in level?	CLS and/or Component and/or Device initiates correct response of \geq 5%?	Duration of step in test	Correct state 3 operation
7						
8						

State 3 Reset

These tests are to demonstrate compliance with section EREC G100 4.5.2.

Please document how the reset from state 3 to state 1 has been demonstrated. Please include how the reset is achieved.

Please confirm that for **CLSs** to be installed in **Domestic installations** three (3) resets causes lockout or that for non-domestic installations lockout can only be reset after four hours. Please explain how lockout is reset.

Appendix C – CLS Installation and Commissioning Tests

This form is available in a Microsoft Word version from the ENA's website.

G100/2 - Form C: Installation Document for Customer Export or Import Limitation Schemes (CLS)	
Part 1 shall be completed for the installation. Part 2 shall be completed for [each of] the CLS being commissioned.	
Form C Part 1	
To ABC electricity distribution DNO 99 West St, Imaginary Town, ZZ99 9AA abcd@wxyz.com	
Customer Details:	
Customer (name)	
Address	
Post Code	
Contact person (if different from Customer)	
Telephone number	
E-mail address	
MPAN(s)	
Customer signature	
Installer Details:	
Name	
Accreditation / Qualification	
Address	
Post Code	

Contact person						
Telephone Number						
E-mail address						
Signature						
Installation details:						
Address						
Post code						
Location within Customer's Installation						
Summary details of Devices within the Customer's Installation						
Manufacturer / Reference (including ENA Type Test Register system reference)	Date of Installation	Nature of loads, sources of energy and conversion technology etc:	Device capacity (A)			
			3-Phase Units	Single Phase Units		
				PH1	PH2	PH3

Form C Part 2	
Commissioning Checks	
Description	Confirmation
Customer's Installation satisfies the requirements of BS7671 (IET Wiring Regulations)?	Yes / No*
Schematic diagram and all relevant Manufacturer's and Installer's information safely retained on site?	Yes / No*
Operation diagram (if required, ie for export control) displayed correctly on site?	Yes / No*
Communication/Power supply failure tests?	Yes / No*
Fail Safe Tests (Form B and/or ENA Type Test register system reference) completed successfully in full	Yes / No*/Ref
Final test to confirm no inappropriate control cycling or hunting	Yes/No*
Operational tests completed (Form B or Manufacturer's reference)	Yes / No*/Ref
*Circle as appropriate. If "No" is selected the CLS is deemed to have failed the commissioning tests and the CLS shall not be put in service.	
<p>Overload or Reverse Power Protection</p> <p>If fitted, please state settings here:</p> <p>Please state what tripping action the protection initiates:</p> <p>Confirm that the protection has been tested and please provide the test results:</p>	
Additional comments / observations:	

Declaration – to be completed by Customer or Installer	
I declare that for the CLS , and the installation:	
<ol style="list-style-type: none"> 1. Compliance with the requirements of EREC G100 is achieved. 2. The commissioning checks detailed in this Form C have been successfully completed. 	
Name:	
Signature:	Date:
Company Name:	
Position:	
Declaration – to be completed by DNO Witnessing Representative if applicable. Delete if not witnessed by the DNO	
I confirm that I have witnessed the commissioning checks detailed in this Form C	
Name:	
Signature:	Date:
Company Name:	

Appendix D – Examples

Example 1 – Large PV installation at a Domestic Installation

A domestic **Customer** wishes to install a PV system but the **DNO** has restricted the **MEL** to 16A due to concerns over voltage rise. The cut-out fuse rating is 80A. A **CLS** is to be installed so that the capacity of the PV installation can be maximised.

Figure E 1 - Large PV Installation at a Domestic property

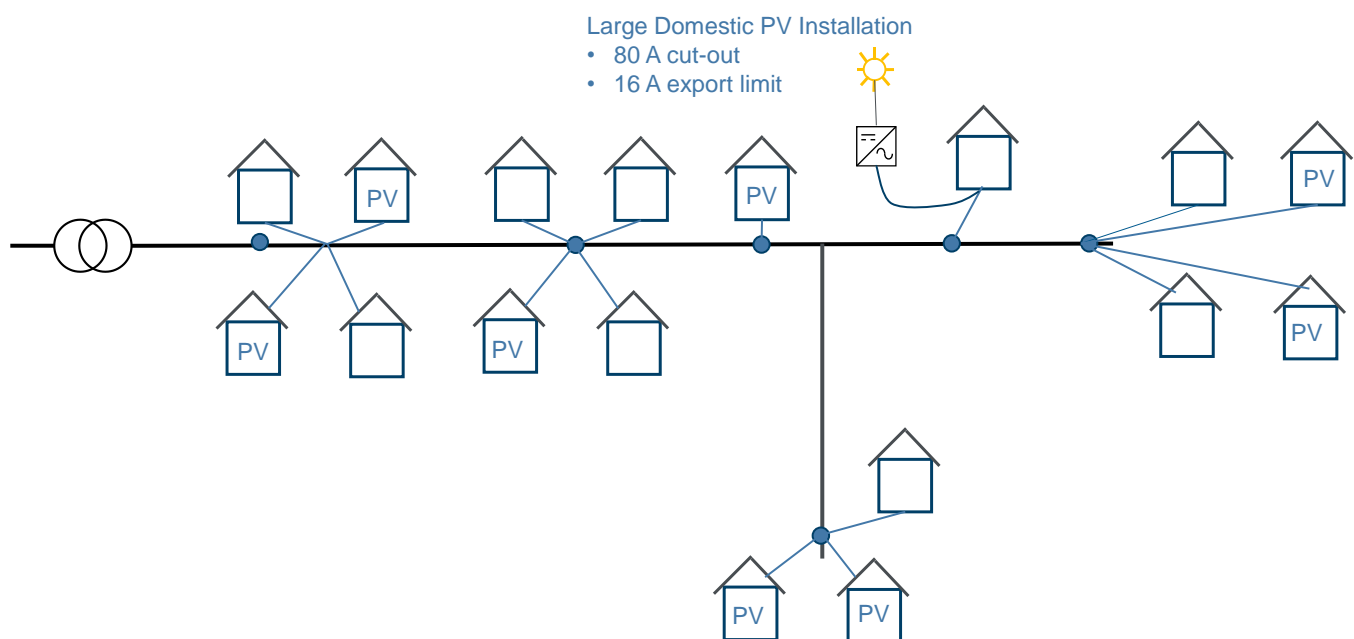

The **DNO** determines the maximum acceptable installed generation capacity, as follows:

Thermal Assessment:

The continuous rating of the cut-out and service cable are both in excess of 80A (18.4kW) and the state 2 five minute **Distribution System** capability is substantially higher than this. The **DNO** determines that the thermal rating of the installation does not, in practice, limit the capacity of the PV system.

Protection Assessment:

The protection assessment restricts the state 2 limit to 1.45 x the cut-out fuse rating, ie 116A or 26.7kW.

Voltage Assessment:

The highest voltage that can be accepted on the **LV** network in state 2 is 112% of the nominal voltage = $253V + 2 = 112\%$ of 230V = 257.6V.

The **DNO** calculates that when 10kW of generation is connected at the property the voltage at the end of the circuit reaches 257.6V.

Conclusion

If a **CLS** is installed that limits the export to 16A the maximum acceptable generation capacity is the lower the results from the state 2 thermal assessment, protection assessment and voltage assessment. In this case the generating capacity, ie the aggregate rating of the PV inverters, must be no higher than 44A (ie 10kW at nominal voltage and unity power factor).

PV inverters up to 44A can be installed, but the **DNO** requires that the **MEL** is restricted to 16A (with a **CLS** set to 16A) to prevent the voltage on the **LV** network exceeding the maximum statutory voltage limit of $230V + 10\% \text{ of } 230V = 253V$.

Example 2 –Wind Turbine Installation at a Farm

A farmer would like to install a wind turbine with a capacity of 200kW. The farm has an **LV** connection with an **MIL** of 200kW (3 phase) but does not have an **MEL**. The cut-out fuses are 300A.

After carrying out a design study the **DNO** is only able to offer a **MEL** of up to 220A (152kW) due to the voltage rise at the **Connection Point**. The **Installer** recommends the use of a **CLS** to allow the 200kW wind turbine to be installed.

Figure E 2 - Wind Turbine Installation at a Farm

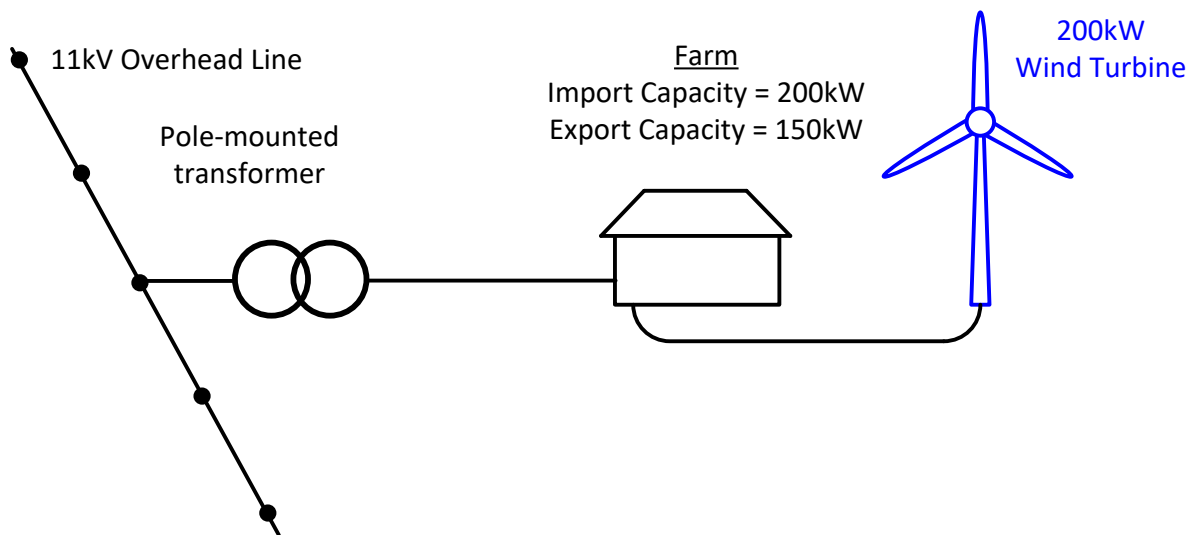

The **DNO** carries out the following assessments:

Thermal Assessment

The **DNO** establishes that the existing **HV** and **LV** network can accommodate 220A of export continuously (at nominal voltage and unity power factor) and substantially more than 290A (200kW) of export for the state 2 thermal limit.

Protection Assessment:

The protection assessment restricts the state 2 limit to $1.45 \times 300A = 435A$ (300kW)

The proposed 200kW wind turbine satisfies the state 2 protection assessment.

Voltage Assessment:

The **DNO** assesses the generator's impact on the **LV** network voltage and the **HV** network voltage under minimum demand / maximum generation conditions. The voltage rise on the **HV** network voltage is found to be minimal but the **LV** voltage is calculated to rise to 257V when the 200kW wind turbine operates at its maximum capacity (at unity power factor).

The highest voltage that can be accepted on the **LV** network in state 2 is 112% of the nominal voltage = $253V + 2 = 112\%$ of $230V = 257.6V$.

The estimated value of $257V$ satisfies this requirement.

Conclusion

The proposed 200kW wind turbine is below the maximum acceptable generation capacity with a suitable **CLS**. If a **CLS** is installed that limits the export to 152kW (ie 220A at nominal voltage and unity power factor), the proposal is acceptable.

Example 3 – A new PV farm connection

A **Customer** wishes to install a 5MW PV farm in a rural area. The PV farm also requires an import capability of 100kW to power the ancillary supplies.

The connection to the **HV** network is via a metering circuit breaker with IDMT relay protection set to 400A, 0.15tm.

The **DNO** carried out an assessment and offered a **MEL** of 120A (2.3MW at nominal voltage and unity power factor) pending reinforcement works. Once the network has been reinforced the full 5MW export capacity can be provided.

The **Customer** proposes to temporarily install a **CLS** until the reinforcement works are completed to maximise the capacity of PV installation during the interim period.

Figure E 3 – New PV Farm

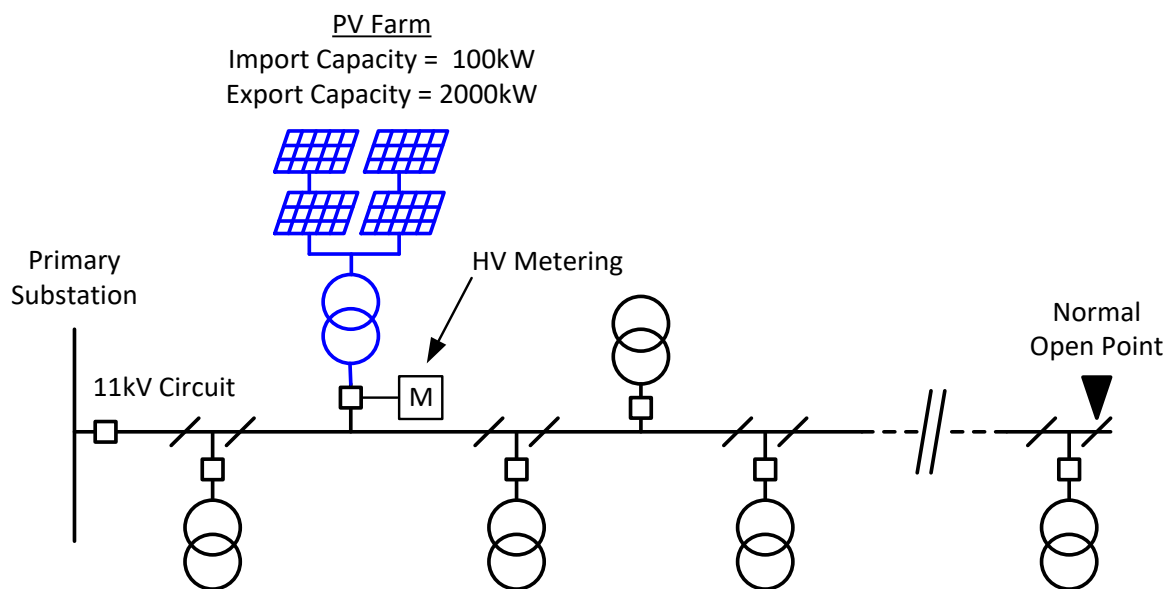

The **DNO** assesses the maximum generation capacity, as follows:

Thermal Assessment

The **DNO** assesses the network is capable of withstanding an export of 240A (4.6MW at nominal voltage and unity power factor) for the state 2 design time of five minutes.

Protection Assessment

The relay is set to 400A; the maximum unrestricted export from the site would be 250A.

The protection does not present any limitations.

Voltage Assessment:

The **DNO** assesses the generator's impact on the 11kV network under minimum demand / maximum generation conditions. The **DNO** specifies an upper voltage limit of 11.2kV to prevent the voltage on the local **LV** network from exceeding statutory limits.

For the purposes of assessing the maximum acceptable generation capacity the voltage must not exceed upper voltage limit + (2% of the nominal voltage) = 11.2kV + (2% of 11kV) = 11.42kV during the state 2 operating time of the **CLS**.

The **DNO** calculates that the voltage will increase to 11.42kV if the site exports 4.8MW (at unity power factor).

Conclusion

If a **CLS** is installed with a **MEL** of 120A (that limits the export to 2.3MW) the maximum acceptable generating capacity (ie the maximum capacity of the PV farm) is the lower of results from

- the thermal assessment (4.6MW);
- the voltage assessment (4.8MW); and
- the protection assessment (9.5MW).

In this case the generating capacity must be temporally restricted to 240A (4.6MW) until the reinforcement work is completed (eg by not connecting all the PV arrays).

Example 4 – A new CHP connection

A **Customer** wishes to install a 3MW CHP installation in an existing industrial installation. There is no existing generation on the site. The site maximum demand is 1.5MW. There is significant (5MW) of generation already installed on the same 11kV feeder.

The connection to the **HV** network is via a metering circuit breaker with relay protection set to 200A, 0.15tm.

The **DNO** carried out an assessment and can offer a maximum export capacity of 100A (ie 1.91MW at unity power factor and nominal voltage). This will enable normal operation of the site, but will pose problems when the site demand drops below 1.09MW and the generation is running at full output.

Thermal Assessment

The **DNO** assesses the network is capable of withstanding an export of 10MW (at nominal voltage and unity power factor) for the state 2 design time of five minutes.

Protection Assessment

The relay is set to 200A; the maximum unrestricted export from the site could be 171A.

The protection does not present any limitations.

Voltage Assessment:

The **DNO** assesses the generator's impact on the 11kV network under minimum demand / maximum generation conditions. The **DNO** specifies an upper voltage limit of 11.2kV to prevent the voltage on the local **LV** network from exceeding statutory limits.

For the purposes of assessing the maximum acceptable generation capacity the voltage must not exceed upper voltage limit + (2% of the nominal voltage) = 11.2kV + (2% of 11kV) = 11.42kV during the state 2 operating time of the **CLS**.

The **DNO** calculates that the voltage will increase to 11.42kV if the site exports 184A (ie 3.5MW.)

Conclusion

In this case the proposed 3MW generator is below the maximum acceptable generation capacity (at nominal voltage and unity power factor) and therefore if a **CLS** is installed with a **MEL** that limits the export to 100A (ie 1.91MW at unity power factor), the proposal is acceptable.

Example 5 – Domestic EV charging

A **Customer** wishes to install 2 x 7kW EV chargers at their domestic **Customer's Installation**. The **Customer** has a typical loads and installation. The installation does not include an electric shower or any other high power appliances. The typical maximum demand of the installation without the EV chargers is 2kW, with short term peaks of 8kW.

The installation is connected to the **DNO's** network via an 80A cut-out.

A **CLS** is installed which is intended to limit the maximum import to 72A.

Figure E 4 Domestic EV Charging

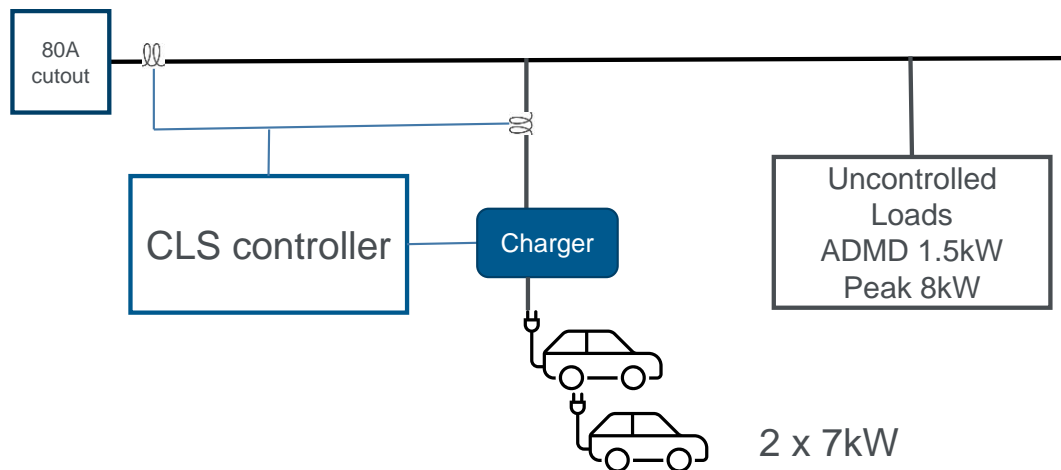

Thermal Assessment

The continuous rating of the cut-out and service cable are both in excess of 80A (18.4kW) and the state 2 five minute **Distribution System** capability is substantially higher than this. The **DNO** determines that the thermal rating of the installation does not, in practice, limit the capacity of the EV system.

Protection Assessment

The protection assessment restricts the state 2 limit to 1.45 x the cut-out fuse rating, ie 116A or 26.7kW.

Voltage Assessment

The **DNO** assesses the maximum instantaneous demand that can be supported whilst maintaining the minimum statutory voltage is 35kW.

Conclusion

In this case the state 2 limit is set by the protection criterion, ie 26.7kW, which is 4.7kW above the maximum possible demand ($8\text{kW} + 2 \times 7\text{kW} = 22\text{kW}$) of the installation. The proposal is acceptable.

If the installation had included an electric shower, for example, the potential instantaneous maximum demand would be too large for an 80A fuse and the **DNO** would need to upgrade the cut-out and/or cut-out fuse.

Example 6 – Commercial EV charging

A **Customer** wishes to install 50 x 22kW EV chargers (ie aggregate capacity 1100kW) in a supermarket car park.

The supermarket has an existing connection with a **MIL** of 300kW, supplied from an 11kV 1000kVA transformers with 500kW of spare capacity. The installation's existing maximum demand is 220kW.

The intention is to seek an increased **MIL** of 650kW, and to use a **CLS** to ensure the EV charging load is modulated such that the **MIL** is not exceeded.

Figure E 5 Commercial EV Charging

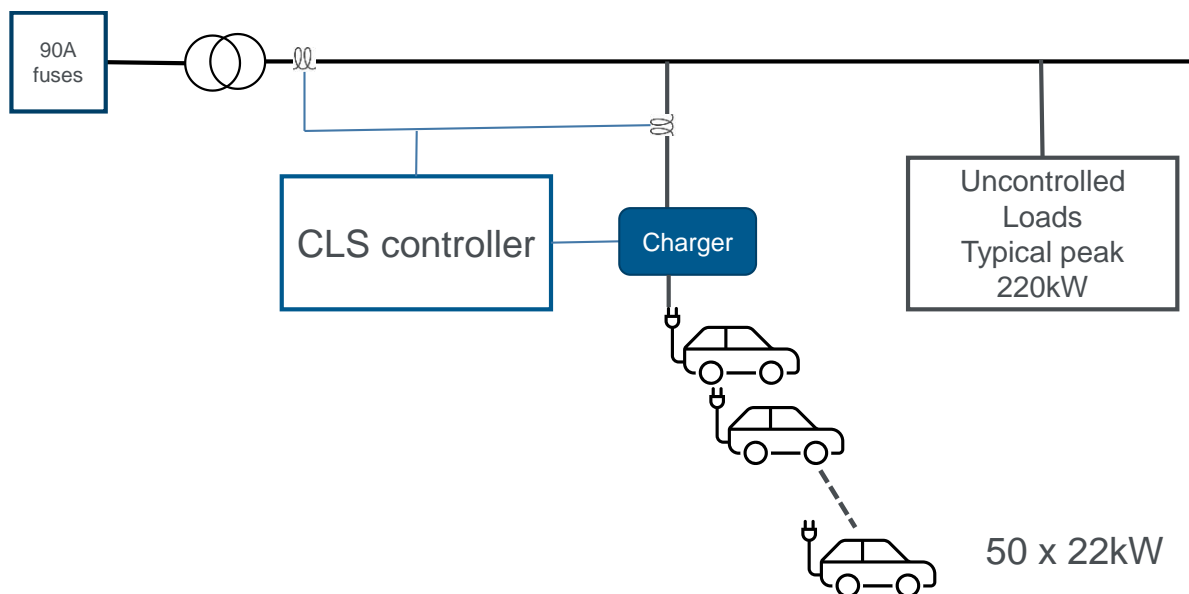

Thermal Assessment.

The **DNO** assesses that the **DNO's** network can withstand 1700kW for five minutes.

Protection Assessment.

The maximum instantaneous power that can be supported on the 90A HV fuses controlling the transformer is 2480kW.

Voltage Assessment

The **DNO** assesses the maximum instantaneous demand that can be supported whilst maintaining the minimum statutory voltage is 3000kW.

Conclusion

In this case the limit on the installed capacity, ie setting the state 2 limit, is the thermal capacity of the **DNO**'s network at 1700kW. The installed capacity of the supermarket and its proposed EV chargers is 1320kW, comfortably within the state 2 limit. The proposal is acceptable and can proceed with no reinforcement required.

Example 7 – Use of Overload Protection

A **Customer** wishes to install 50 x 22kW EV chargers (aggregate capacity 1100kW) in a supermarket car park, but limit the collective demand of the chargers rather than fit a **CLS**.

The supermarket has an existing connection with a **MIL** of 300kW supplied from an 11kV 1000kVA transformers with 500kW of spare capacity. The installation's existing maximum demand is 220kW.

The intention is to seek an increased **MIL** of 650kW, and to use overload protection to ensure the EV charging load is modulated such it never exceeds 350kW (ie 507A).

There are two options:

- (a) install the overload protection as part of the EV charger installation
- (b) install overload protection for the whole installation.

Figure E 6 Overload Protection Option (a)

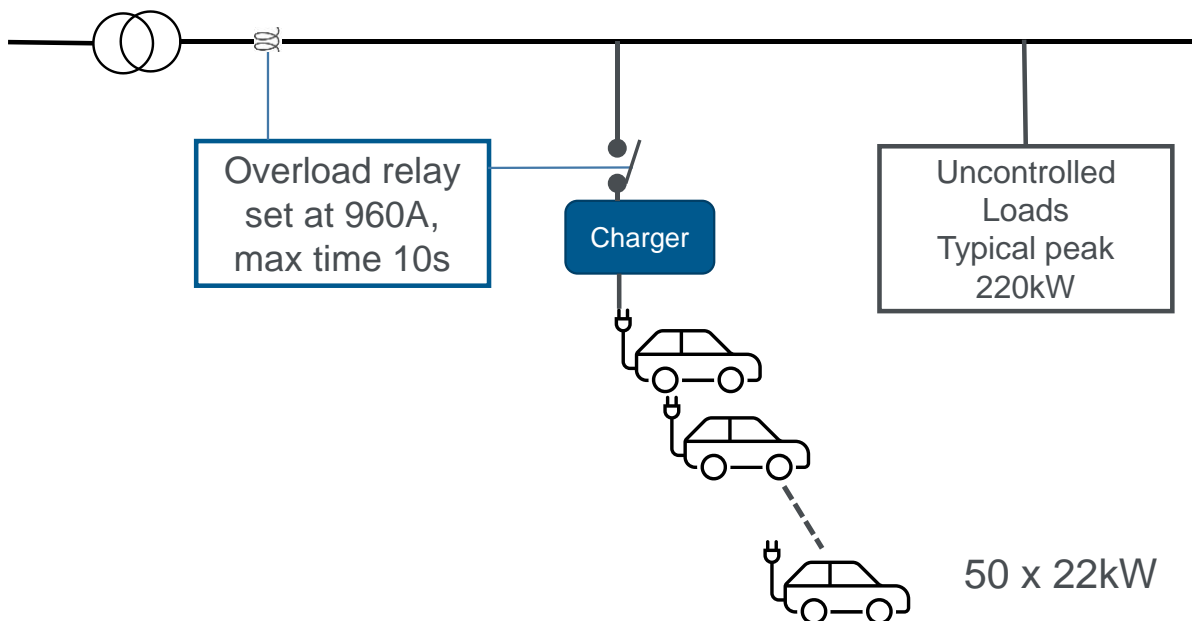
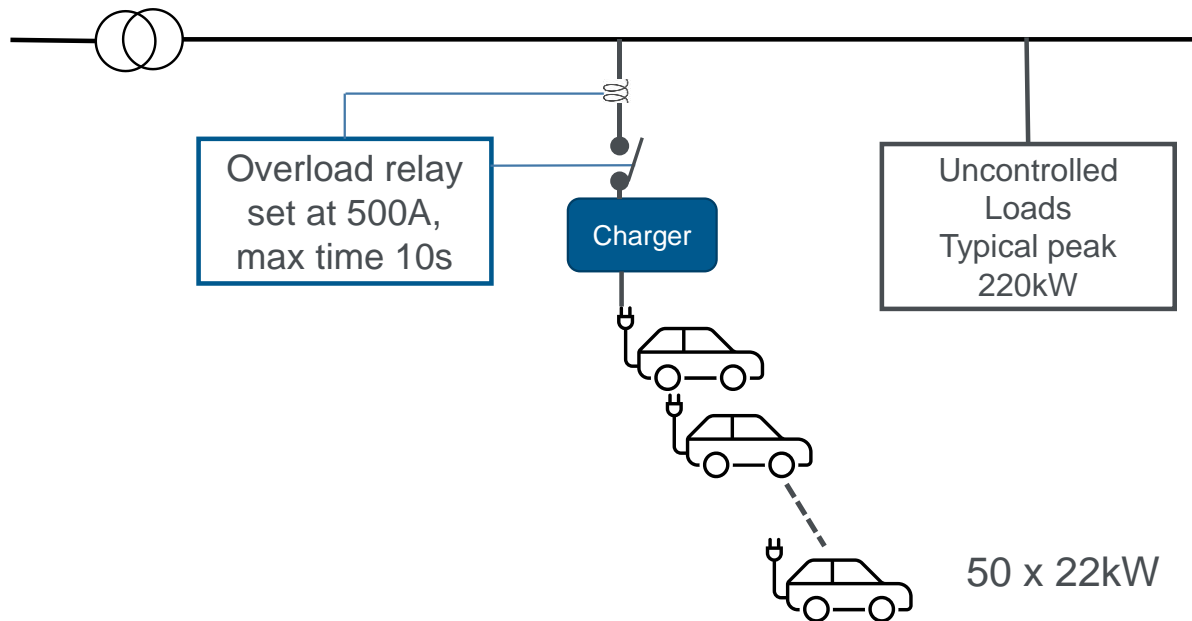

Figure E 7 Overload Protection Option (b)



Thermal Assessment.

The **DNO** assesses that the **DNO's** network can withstand 1700kW for five minutes.

Protection Assessment.

The maximum instantaneous power that can be supported on the 90A HV fuses controlling the transformer is 2480kW.

Voltage Assessment

The **DNO** assesses the maximum instantaneous demand that can be supported whilst maintaining the minimum statutory voltage is 3000kW.

Overload protection setting for the two options:

- (a) **MIL** is 650kW, 942A. Overload shall be set 2% greater than this – ie 960A, to grade with **DNO's** protection. Maximum operating time 10s.
- (b) EV charger demand is constrained to be 350kW, 507A. If 507A is not an available setting, the next lowest setting of 500A shall be selected, again to grade with **DNO's** protection. Maximum operating time 10s.

Conclusion

Provided the **DNO** is satisfied that the protection operating characteristics are appropriate, and that the installation is sufficiently tamper-proof, no **CLS** is required.