

DATE: 20[●]

FLEXIBILITY SERVICES AGREEMENT

Between

ELECTRICITY NORTH WEST LIMITED
(as the Company)

and

[PROVIDER]
(as the Provider)

Note: This Flexibility Services Agreement is intended to standardise the provision of Flexibility Services to Network operators. Please note that the project-specific details, timings and power requirements will be adapted for the particular Provider and Flexibility Services in question and placed within the appropriate schedules

THIS AGREEMENT is made on

20[●]

BETWEEN:

- (1) [●] LIMITED/PLC, a company incorporated in [England and Wales] [Scotland] (registered number [●]) whose registered office is at [●] (the “Company”); and
- (2) [●] LIMITED/PLC, a company incorporated in [England and Wales] [Scotland] (registered number [●]) whose registered office is at [●] (the “Provider”).]

(together the “Parties” and each a “Party”).

RECITALS:

- (1) The Company, as owner and operator of the local Network, requires the provision of Flexibility Services (as hereinafter defined) to aid the management and operation of its Network. The Company wishes to contract with providers and/or operators of suitable assets for the provision of such Flexibility Services.
- (2) The Provider is the owner and/or operator of assets or has entered into arrangements for rights in respect of third party owned assets that have the capability to provide Flexibility Services and wishes to make available each Site for the provision of such Flexibility Services. The Company will pay the Provider for these Flexibility Services in accordance with this Agreement.
- (3) The Company wishes to appoint the Provider to provide the Flexibility Services and the Provider has agreed to provide the Flexibility Services to the Company, on and subject to the terms and conditions contained herein.

The Parties hereby confirm that this Flexibility Services Agreement including Schedules shall incorporate the Conditions of Contract (a copy of which is attached) (the “Conditions”) and together the Flexibility Services Agreement and the Conditions shall be construed as one agreement (the “Agreement”). The priority of such documents shall be as set out below:

- (1) this Flexibility Services Agreement and the Schedules attached; and
- (2) the Conditions.

Terms used herein and not defined shall have the meaning given to them in the Conditions.

PART 1 – Details of the Flexibility Provider and Special Conditions

Provider	Provider’s company number and registered office
[●]	[●]
Contract number	[●]
Provider’s addresses for notices	[●] Address: [●] Contact Number: [●] For the attention of: [●]
Company’s addresses for notices	[●] Address: [●] Contact Number: [●]

	For the attention of: [●]
Provider's Nominated Person	[●]
Company's Nominated Person	[●]
Special Conditions	
The following provisions shall apply to the Agreement and, in the event of conflict, shall override the Conditions:	
1. ADDITIONAL TERMS	
<i>[Insert additional terms, if any]</i>	

PART 2 – Commencement and Expiry Dates

Commencement Date	[●]
Expiry Date	As set out in Schedule 1

**[Note: the following signature blocks should be used if the Agreement is to be governed by English law.
Scottish law signature blocks are on page 23 and must remain on this page]**

Signed by the duly authorised representatives of the Parties as an agreement on the date first written above

Signed)
)
)
for and on behalf of)
[COMPANY])
Director/Duly Authorised Signatory

Signed)
)
)
for and on behalf of:)
[PROVIDER])
Director/Duly Authorised Signatory

TABLE OF CONTENTS

CONDITIONS

1.	Definitions and Interpretation	1
2.	Duration and Term	6
3.	Scope of Flexibility Services	6
4.	Variation	7
5.	Discretionary Flexibility Services	7
6.	Monitoring and Equipment.....	8
7.	Records and Audit.....	9
8.	Insurance	9
9.	Provider’s Obligations.....	10
10.	Representations and Warranties	10
11.	Charges and Payment	12
12.	Termination	13
13.	Service Failure and Material Breach.....	15
14.	Force Majeure.....	16
15.	Indemnity.....	16
16.	[Assignment, <i>NOTE: IF ENGLISH</i>] [ASSIGNATION, <i>NOTE: IF SCOTTISH</i>] Sub-Contracting and Change in Ownership	17
17.	Confidentiality.....	18
18.	Intellectual Property Rights.....	19
19.	Company Property	19
20.	Data Protection	19
21.	Modern Slavery, Anti-Bribery and Living Wage.....	19
22.	Notices	20
23.	Dispute Resolution	21
24.	Severance.....	21
25.	Third Party Rights.....	21
26.	No Agency or Partnership	22
27.	Waiver.....	22
28.	Entire Agreement.....	22
29.	Counterparts.....	22
30.	Governing Law and Jurisdiction	22
	Schedule 1 Service Description	25
	Schedule 2 Flexibility Service Charges	32
	Schedule 3 Sites/DER.....	35
	Schedule 4 Communications	36
	Schedule 5 Performance Monitoring	43
	Schedule 6 Technical Requirements.....	45

CONDITIONS

1. DEFINITIONS AND INTERPRETATION

In this Agreement and the recitals, unless the context otherwise requires, the following expressions shall have the meanings set out below:

“Accepted End Time” means the date and time (to the nearest minute) as notified in accordance with Clause 3 and/or 5 at which the Accepted [MW/MVAR] is no longer required to be delivered;

“Accepted [MW/MVAR]” means the [MW/MVAR] accepted in accordance with Clause 3 and/or 5;

“Accepted Start Time” means the date and time (to the nearest minute) as notified in accordance with Clause 3 and/or 5 at which the Accepted [MW/MVAR] shall be delivered;

“Affiliate” means any holding company or subsidiary company of a Party, or any company which is a subsidiary of such holding company and **“holding company”** and **“subsidiary”** have the meanings given in section 1159 of the Companies Act 2006;

“Applicable Law” means any applicable law, statute, by-law, regulation, order, regulatory policy, guidance or industry code, rule of court or directives or requirements of any regulatory body;

“Available” means that the Flexibility Services, in accordance with the Service Requirements and the Utilisation Instruction, are available to be delivered to the Company for the duration of the Service Window;

“Availability Fee” means the fee payable in consideration for the Provider making available the Available the DER and calculated in accordance with the provisions of Schedule 2;

“Availability Status” means Available or Unavailable;

“Authority” means the Gas and Electricity Markets Authority;

“Business Hours” means between 9:00 am and 5:00 pm on a Business Day;

“Business Day” means any day other than a Saturday or a Sunday or a bank holiday in [England and Wales] [the City of Edinburgh]; ***[Note: Please delete as appropriate England and Wales or Scotland depending on location of the Site]***

“Change in Ownership” means:

- a) any sale, transfer or disposal of any legal, beneficial or equitable interest in fifty per cent (50%) or more of the shares in the Provider (including the control over the exercise of voting rights conferred on those shares, control over the right to appoint or remove directors or the rights to dividends); and/or
- b) any other arrangements that have or may have or which result in the same effect as sub-clause a) above.

“Charges” means the charges set out in Schedule 2 of this Agreement;

“Commencement Date” means the date set out in Part 2 of this Agreement;

“Confidential Information” means any information, however it is conveyed, that relates to the business, affairs, developments, trade secrets, know-how, personnel, customers and/or

suppliers of a Party (and/or any its Affiliates) together with all information derived from the above, and any other information clearly designated as being confidential (whether or not it is marked as “confidential”) or which ought reasonably to be considered to be confidential;

“**Connection Agreement**” means any agreement governing the terms of connection of any plant or apparatus to, and/or any agreement for the supply of electricity to the plant or apparatus or for the acceptance of electricity into, and its delivery from, the Company’s electricity distribution Network;

“**Data Protection Law**” means any applicable law relating to the processing, privacy, and use of personal data, as applicable to the Company, the Provider and/or the Flexibility Services, including in the UK: (i) the Privacy and Electronic Communications (EC Directive) Regulations 2003 and any current laws or regulations implementing Council Directive 2002/58/EC; and/or (ii) the General Data Protection Regulation (EU) 2016/679 (“**GDPR**”), and/or any corresponding or equivalent national laws or regulations, once in force and applicable, including the Data Protection Act 2018, and includes any judicial or administrative interpretation of them, any guidance, guidelines, codes of practice, approved codes of conduct or approved certification mechanisms issued by any relevant supervisory authority;

“**Disclosing Party**” means the Party disclosing Confidential Information to the Receiving Party;

“**Discretionary Flexibility Services**” means additional Flexibility Services requested by the Company outside of or in addition to the Service Requirements detailed within this Agreement;

“**Discretionary Service Periods**” means in respect of a DER, periods during the Term of the Agreement that are not Service Periods;

“**Discretionary Utilisation Fee**” means the fee for providing Discretionary Flexibility Services as specified in Clause 5 and Schedule 2;

“**Discretionary Utilisation Request**” means a request for Flexibility Services from the Company in respect of a DER during a Discretionary Service Period;

“**Dispatch Equipment**” means any equipment (including any routers, computers, input / output notes and cables and software) owned by the Company and provided in respect of the provision of the Flexibility Services under this Agreement;

“**Distributed Energy Resources**” or “**DER**” means the electricity generators, electricity storage or electrical load, and other Site and Provider equipment, machinery, apparatus, materials and other items used for the provision of the Flexibility Services as described in Schedule 3;

“**Distribution Code**” means the Distribution Code of Licenced Distribution Network Operators of Great Britain;

“**Distribution Licence**” means a licence issued under section 6(c) of the Electricity Act 1989;

“**Distribution Licensee**” means a holder of Distribution Licence within the same Group of companies as the Company;

“**Due Date for Payment**” has the meaning given to it in Clause 11.7;

“**Electricity Regulations**” means the Electricity Act 1989, the Utilities Act 2000, the Energy Acts 2008 – 2016, the National Terms of Connection and any other licences, codes or industry agreements related to such legislation;

“**Expiry Date**” means the date this Agreement expires, as defined in the Agreement and as can be extended pursuant to Clause 2;

“Flexibility Provider” means the provider set out in Part 1 of this Agreement;

“Flexibility Services” means, and more particularly described in Schedule 1, the services to be provided by the Provider to the Company under and in accordance with this Agreement which give the Company the ability to manage the load at a specific point of the Network at certain points in time;

“Force Majeure” means any event or circumstance which is beyond either the Company’s or the Provider’s (as the case may be) reasonable control or its employees and which results in or causes its failure to perform any of its obligations under the Agreement, provided that: (a) lack of funds; or (b) any failure or fault in the DER, including insufficient fuel, shall not constitute Force Majeure;

“Good Industry Practice” means the exercise of the degree of care, skill and diligence, which would reasonably be expected from an experienced and competent person carrying out services of a similar nature, scope and complexity as the Flexibility Services;

“Grid Code” means the technical code for connection and development of the National Electricity Transmission System (available at www.nationalgrid.com/uk/electricity/codes/grid-code?code-documents);

“Group” means in relation to a company, that company, any subsidiary or holding company of that company, and any subsidiary of a holding company of that company. For the purposes of this definition the terms “holding company” and “subsidiary” shall have the meanings assigned to them by section 1159 of the Companies Act 2006;

“Intellectual Property Rights” means patents, rights in or to inventions, copyright and related rights, trademarks, service marks, business names, rights in get-up goodwill and the right to sue for passing off, rights in designs, rights in domain names and website addresses, rights in computer software, database rights, rights to use and protect the confidentiality of, confidential information (including know-how) and all other intellectual property rights, in each case whether registered or unregistered and including all applications and rights to apply for and be granted, renewals or extensions of, and rights to claim priority from, such rights and all similar or equivalent rights or forms of protection which subsist or will subsist now or in the future in any part of the world;

“Insolvency Event” means a Party becoming insolvent or entering into liquidation or receivership or being the subject of an application for an administration order or suffering an administrative receiver or similar officer to be appointed in relation to the whole or any part of its assets or convening a meeting to make a composition or voluntary arrangement with its creditors or suffering any material judgement to be executed in relation to any of its property or assets or if an encumbrancer takes possession of or sells any Party’s assets or if an application is made to a court of competent jurisdiction by a Party for protection from its creditors generally or if any other steps are taken for the winding up of that Party (otherwise than for the purpose of an amalgamation or reconstruction) including the passing of a resolution for the Party’s winding-up or the making by a court of competent jurisdiction of an order for the winding-up or the dissolution of that Party;

“Loss” means any direct loss, damage, cost or expense;

“Material Adverse Effect” means any event or circumstance which, in the opinion of the Company:

- c) is likely to materially and adversely affect the Provider’s ability to perform or otherwise comply with all or any of its obligations under this Agreement; or
- d) is likely to materially and adversely affect the business, operations, property, condition (financial or otherwise) or prospects of the Company.

“MPAN” means a meter point administration number;

“MSA Offence” has the meaning given to it in Clause 21.1.1a);

“MSID” means a metering system identifier;

“Network” means the electricity network operated by the Company to which the DER is connected;

“Nominated Person” means the persons appointed by the Provider and the Company to be responsible for ensuring the performance of this Agreement;

“Non-Operational Notice” means a formal notice as described in Clause 22;

“Performance Report” means a report in relation to the Flexibility Services provided by a DER, or groups of DER responding to Utilisation Instructions and Discretionary Utilisation Requests in accordance with Schedule 5;

“Proving Test” means the tests, more particularly described in Schedule 5, undertaken in accordance with Clause 6.4;]

“Receiving Party” means the Party receiving Confidential Information from the Disclosing Party;

“Recovery Time” means the minimum time required between the end of a Flexibility Service delivery and the commencement of the next Flexibility Service delivery, as defined in Schedule 1;

“Requested End Time” means the date and time (to the nearest minute) as notified in accordance with Clause 3 and/or 5 at which the Requested MW is no longer required to be delivered;

“Requested MW” means the MW requested in accordance with Clause 3 and/or 5;

“Requested Start Time” means the date and time (to the nearest minute) as notified in accordance with Clause 3 and/or 5 at which the Requested MW shall be delivered;

“Schedules” means the Schedules annexed to and forming part of this Agreement;

“Service Failure” meaning is defined in Schedule 1;

“Service Meter” means the measuring equipment, as defined by the Company in Schedule 5 of this Agreement, that shall be used to determine delivery of the Service;

“Service Meter Data” means the meter data recorded at the Service Meter at the Site(s) listed in Schedule 5;

“Service Period” means the period as specified in Schedule 1;

“Service Requirements” means the specification that the Flexibility Services must be capable of meeting, as defined in Schedules 1 and 6;

“**Service Window**” means the time periods during the Service Period during which the Provider agrees to make Available, and provide in accordance with this Agreement, the Flexibility Services to the Company, as defined in Schedule 1;

“**Sites**” means the Provider’s sites which are detailed in Schedule 3;

“**Statutory Requirements**” means the requirements placed on the Company and/or the Provider or affecting or governing the provision and/or use of the Flexibility Services by Applicable Law and/or the Distribution Licence and/or a Regulator and/or any relevant codes of practice issued by any government agency or body including in relation to health, safety and environmental matters;

“**Stop Instruction**” means an instruction from the Company to the Provider, instructing the Provider to cease delivery of the Flexibility Services, as more particularly described in Schedule 4;

“**Term**” has the meaning given to it in Clause 2;

“**Testing and Commissioning Test**” means the tests, more particularly described in Schedule 5, undertaken to determine whether the Flexibility Services can be delivered in accordance with the Service Requirements and an Instruction;

“**Transmission Licensee**” means a holder of a licence issued under section 6(b) of the Electricity Act 1989;

“**Unavailable**” means that the Flexibility Services, in accordance with the Service Requirements, are not available to be delivered to the Company;

“**Utilisation Fee**” means the amount payable by the Company to the Provider for the utilisation of any Flexibility Service, as defined in Schedules 2;

“**Utilisation Instructions**” means an instruction by the Company to the Provider to deliver Flexibility Services in accordance with Schedule 4;

“**VAT**” value added tax as provided for in the Value Added Tax Act 1994 and any other tax of a similar nature;

“**Zone**” means the feeding area of the DERs being managed or where the Flexibility Services will be provided and to which the Flexibility Services will be delivered.

1.2 In this Agreement, unless the context otherwise requires:

1.2.1 the singular includes the plural and vice versa;

1.2.2 reference to a gender includes the other gender and the neuter; and

1.2.3 references to an act of Parliament, statutory provision or statutory instrument include a reference to that act of Parliament, statutory provision or statutory instrument as amended, extended or re-enacted from time to time and to any regulations made under it.

1.3 Any phrase introduced by the terms “**including**”, “**include**”, “**in particular**” or any similar expression shall be construed as illustrative and shall not limit the sense of the words preceding those terms.

1.4 If there is any conflict between the Flexibility Services Agreement and any part of the Schedules, subject to Clause 1.6, the former shall prevail.

1.5 If there is any conflict between the Schedules and the Conditions, subject to Clause 1.6, the former shall prevail.

1.6 To the extent that the terms of this Agreement conflict with any of the rights or obligation of the Parties under the Electricity Regulations, the terms of the Electricity Regulations shall prevail.

2. DURATION AND TERM

2.1 This Agreement shall commence on the Commencement Date and, subject to earlier termination in accordance with Clause 12, shall continue until the Expiry Date, such period being the “Term”.

2.2 This Agreement shall terminate automatically on the Expiry Date without notice, unless extended pursuant to Schedule 1.

2.3 The Company may give the Provider reasonable notice in writing prior to the Expiry Date that the Term is extended. Extensions of the Term pursuant to this Clause 2.2 shall be limited in number and duration as set out in Schedule 1.

3. SCOPE OF FLEXIBILITY SERVICES

3.1 The Provider shall make its DER Available for provision of the Flexibility Services in accordance with Schedule 1 and in a manner agreed to by the Parties and shall provide written notice of any Unavailability in accordance with Schedule 4. In the event of any emergency or unplanned Unavailability, the Provider shall notify the Company as soon as reasonably practicable.

3.2 The Company may request from the Provider, subject to the Provider’s Availability Status, the provision of the Flexibility Services for Service Periods by issuing a Utilisation Instruction in accordance with Clause 3.4.

3.3 This Agreement is not a guarantee of Utilisation Instructions and does not constitute a contract for the exclusive provision of Flexibility Services. The Company reserves the right to contract with other providers for the type of services covered by this Agreement.

3.4 The provisions of Schedule 4 shall apply in respect of all communications between the Company and the Provider in respect of the Flexibility Services.

Requesting and accepting instructions for Flexibility Services

3.5 Where, and to the extent that a Provider is Available, the Company may request Flexibility Services from the Provider by sending a Utilisation Instruction in accordance with Schedule 4.

3.6 The Company may:

3.6.1 withdraw any Utilisation Instruction by providing written notice to the Provider at any time before the Provider has provided a response under and in accordance with Clause 3.7; and/or

3.6.2 issue a Stop Instruction to the Provider in accordance with Schedule 4.

3.7 The Provider must respond (whether it chooses to accept or not) to the instruction in accordance with the provisions set out in Schedule 4.

Provision of Flexibility Services

- 3.8 Where the Provider accepts a Utilisation Instruction and subject to receipt of any Stop Instruction, the Provider shall provide the Flexibility Services to the Company using the DER in accordance with the Accepted Start Time, Accepted End Time and Accepted [MW/MVAR].
- 3.9 In performing the Flexibility Services pursuant to this Agreement, the Provider must comply with the technical requirements set out in Schedule 6.
- 3.10 No Utilisation Fees shall be due to the Provider by the Company for any Flexibility Services delivered in excess of the Accepted [MW/MVAR].
- 3.11 Where the Provider fails to deliver the Flexibility Services as agreed in Clause 3.7, the Charges shall be reduced in accordance with the performance factor table set out in Schedule 2.

4. VARIATION

- 4.1 Subject to Clause 4.3, no variation of this Agreement shall be effective unless it is in writing and signed by the Parties (or their authorised representatives).
- 4.2 The Provider may, with prior approval of the Company (in its sole discretion), change the DER providing the service(s) detailed in Schedule 3 by providing a minimum of thirty (30) days notice of the change and specifying that the new DER meets the technical, functional and non-functional requirements of the specified service.

Variation to Service Windows

- 4.3 The Company may, with prior written agreement from the Provider, make single or marginal variations to individual Service Windows or power injection requirements within the following boundaries:
- 4.3.1 a Service Window may change by up to one (1) hour inclusive of extension, early instruction or delayed instruction.
- 4.3.2 a power requirement (demand reduction, power injection or other) may be increased or lowered no more than ten per cent (10%) of the contracted requirement.
- 4.3.3 The Company may seek to make service variations of this nature on no more than two (2) occasions in any contractual year, and no more than four (4) times in any contractual term.
- 4.3.4 Any required changes greater than those above must be the subject of either a Discretionary Service or procurement of a new service.

5. DISCRETIONARY FLEXIBILITY SERVICES

- 5.1 From time to time, the Company may at its discretion request from the Provider, and subject to the Provider's Availability Status, additional Flexibility Services for Discretionary Service Periods ("**Discretionary Flexibility Services**").
- 5.2 The Company may request Discretionary Flexibility Services from the Provider by sending a Discretionary Utilisation Request in accordance with Schedule 4.
- 5.3 The Company may:
- 5.3.1 withdraw any Discretionary Utilisation Request by providing written notice to the Provider at any time before the Provider has provided a response under and in accordance with Clause 5.2; and/or

5.3.2 issue a Stop Instruction to the Provider in accordance with Schedule 4.

5.4 The Provider may accept the Discretionary Utilisation Request in accordance with the provisions set out in Schedule 4. The Provider's acceptance in accordance with this Clause 5.4 shall be final and binding.

5.5 Where the Provider fulfils the conditions set out in Clause 5.4 and subject to receipt of any Stop Instruction, the Provider shall provide the Discretionary Flexibility Services to the Company using the DER in accordance with the Accepted Start Time, Accepted End Time and Accepted [MW/MVAR].

5.6 In performing the Discretionary Flexibility Services pursuant to this Agreement, the Provider must comply with the technical requirements set out in Schedule 6.

5.7 If the Provider fails to respond in accordance with Clause 5.4, the Provider will be deemed to have declined the request.

5.8 No Discretionary Utilisation Fee shall be due to the Provider by the Company for any Discretionary Flexibility Services delivered in excess of the Accepted [MW/MVAR].

6. MONITORING AND EQUIPMENT

6.1 Subject to Schedule 5, the Company shall be entitled to, at its sole discretion, monitor, meter and determine the Provider's provision of the Flexibility Services using such data collection and systems as the Company deems appropriate and which may, without limitation, utilise minute by minute metering data analysis techniques for each active DER.

6.2 The Company reserves the right to collect any meter data that it reasonably requires for the purpose of this Agreement from a third party, including but not limited to an electricity supplier, and the Provider undertakes to secure all necessary consents on behalf of the owner or user of the DER, and to perform any action that the Company considers reasonably necessary to facilitate such collection and use of meter data.

6.3 The Company shall assess the availability of Flexibility Services and the amount of Flexibility Services delivered by the Provider and may complete this by reference to a Performance Report. The detail and expected timing of these reports is specified in Schedule 5.

6.4 Should the Company identify a failure affecting the communications or Dispatch Equipment the Company may notify the Provider and that it requires a Proving Test in accordance with the requirements set out in Schedule 5.

7. RECORDS AND AUDIT

7.1 The Provider shall keep or cause to be kept proper and accurate records of all matters relating to the performance of its obligations under this Agreement. The records shall be maintained in a form suitable for audit purposes, shall be kept separate from any other records of the Provider and shall be retained for the period required by any applicable statutory provision and in any event during the Term of this Agreement and for a period of not less than seven (7) years thereafter.

7.2 The Company or a reputable independent third-party auditor nominated by it may, on reasonable notice to the Provider and during normal working hours, inspect and review the records for the purposes of verifying the Provider's compliance with its obligations under this Agreement and/or to meet any other audit or information requirement that may be required by applicable law and/or any regulatory body or the Authority.

7.3 The Provider shall co-operate fully and promptly with any such audit and/or inspection conducted by the Company and whatever reasonable assistance may be required by the Company in relation to any audit.

7.4 The Provider shall take or procure to be taken such steps as may be necessary to ensure that all paperwork issued by or on behalf of the Provider to the Company (including, without limitation, invoices, correspondence and delivery notes), is complete, accurate and clearly references the relevant purchase order date and number and/or contract number.

8. INSURANCE

8.1 The Provider shall procure appropriate insurances as required by law and necessary for the safe and efficient performance of this Agreement with a reputable insurance company, including employer's liability insurance and public liability insurance. Where possible the Provider shall add the Company as a named party on its insurance policies.

8.2 The Provider's insurance shall include an indemnity to the Company as principal only to the extent of its liability under this Agreement.

8.3 If the Provider appoints a sub-contractor in connection with the provision of the Flexibility Services, the Provider shall ensure that the sub-contractor maintains appropriate insurance.

8.4 The Provider shall provide the Company with evidence of the insurance it has in place (and where relevant that of its sub-contractor) when requested to do so by the Company. Where the Company deems the insurance to be inappropriate the Company shall notify the Provider of its concerns and where appropriate insurance is not obtained by the Provider (or its sub-contractor) within three (3) months of that notice, the Company may treat that failure as a material breach for the purposes of Clause 12.1.

8.5 The Provider shall give immediate notice to the Company where any claim under the Provider or its sub-contractor's insurance policy(ies) may impact on the Company and shall provide full details of that claim to the Company.

8.6 The Provider and any relevant sub-contractor shall not negotiate any payment, settlement or admit or repudiate any claim which may impact on the Company, without the written consent of the Company. The Provider shall permit the Company to take proceedings in the name of the Provider (or its Sub-contractor) to recover compensation or secure an indemnity from any third party in respect of matters covered by the insurance, provided that the Company's performance of the same does not put the Provider in breach of the terms and conditions of the insurance. In the event that the Provider's insurers are also entitled to take proceedings in the name of the Provider against any third party in respect of a matter which may impact of the Company, the Provider shall use its best endeavours to facilitate agreement between the Company and the Provider's insurers as to the conduct of those proceedings and the allocation of recoveries.

8.7 The Provider's liabilities under this Agreement shall not be deemed to be released or limited by the Provider taking out the insurance policies referred to in this Clause 8.

9. PROVIDER'S OBLIGATIONS

9.1 The Provider shall:

9.1.1 Ensure or procure the Availability of the DER and perform the Flexibility Services in compliance with this Agreement and all Applicable Laws, Statutory Requirements and Good Industry Practice;

- 9.1.2 own and/or manage the DER during the Term and shall ensure that all technical, communication and data provision requirements set out in Schedule 4 and Schedule 6 are complied with at all times;
- 9.1.3 provide the Flexibility Services in accordance with all UK health, safety and environment legislation and approved codes of practice;
- 9.1.4 remedy any defect of the Flexibility Services with Good Industry Practice and to the satisfaction of the Company;
- 9.1.5 act diligently and in good faith in all of its dealings with the Company;
- 9.1.6 ensure that it is available at all times on reasonable notice to provide such assistance or information as the Company may reasonably require in connection with the Flexibility Services;
- 9.1.7 disclose the existence of any agreement or arrangement the Provider may have in respect of the DER that provides Flexibility Services under this Agreement that could reasonably impact Availability of the DER or the ability of the Provider to perform its obligations under this Agreement;
- 9.1.8 at the request of the Company, make available to the Company information in relation to the metering equipment at the DER, including but not limited to a manufacturers test certificate, single line diagram, and technical information from the manufacturer of the meter, which sets out the typical errors of the meter;
- 9.1.9 permit and grant (or procure) free and unrestricted rights of access to and over and egress from the Site to the Company and/or its agents or sub-contractors (upon reasonable notice) as the Company may reasonably require in order to inspect and test the DER, or to install, maintain, replace or remove communication equipment belonging to the Company in relation to the provision of flexibility services.

10. REPRESENTATIONS AND WARRANTIES

- 10.1 Without prejudice to its other obligations under and/or pursuant to this Agreement, each Party warrants and undertakes to the other Party at all times that:
 - 10.1.1 it is a duly incorporated company validly existing under the law of its jurisdiction of incorporation;
 - 10.1.2 it has the right, power, capacity and authority to enter into and perform its obligations under this Agreement;
 - 10.1.3 the entry into and performance by it of this Agreement does not and will not contravene or conflict with any law or regulation or judicial or official order applicable to it;
 - 10.1.4 it will not be in material breach of any other agreement or arrangement of whatever nature with any person which could or may affect the performance of its obligations under this Agreement;
 - 10.1.5 all information it provides to the other Party will be complete and accurate;
 - 10.1.6 no Insolvency Event is continuing or might reasonably be anticipated; and
 - 10.1.7 no litigation, arbitration or administrative proceedings are taking place, pending, or to the Party's knowledge threatened against it, any of its directors or any of its assets,

which, if adversely determined might reasonably be expected to have a Material Adverse Effect.

- 10.2 Without prejudice to its other obligations under and/or pursuant to this Agreement and in addition to the foregoing, the Provider warrants and undertakes to the Company at all times that:
- 10.2.1 it has either a live connection to the Company's electricity Network and an associated MPAN or MSID and Connection Agreement, or a connection offer pursuant to live connection and that the connection can be completed in time to meet the Service Requirements as specified in Schedule 1;
 - 10.2.2 it has obtained and maintains in force for the Term all licences, permissions, authorisations, consents and permits needed to supply the Flexibility Services in accordance with the terms of this Agreement;
 - 10.2.3 it has neither fixed nor adjusted any Charge under or in accordance with any agreement or arrangement with any other person, and that it has neither communicated to a person (other than its professional advisers) the amount or approximate amount of any Charge (other than in confidence in order to obtain quotations necessary for insurance purposes) nor entered into any agreement or arrangement with any other person to restrain that other person from entering into an agreement for Flexibility Services with the Company;
 - 10.2.4 it shall disclose any change of circumstances which could affect the delivery of the Flexibility Services;
 - 10.2.5 in respect of DER projects in development, the Provider has in place a defined schedule of design, build and commissioning which shall promptly be made available to the Company on request for its review of the same;
 - 10.2.6 if, at any time during the Term, the provision of Flexibility Services would cause the Provider to be in breach or non-compliance as described in Clauses 10.1.3 or 10.1.4, the Provider will not accept any Utilisation Instruction and will provide notification to the Company as required by Schedule 4;
 - 10.2.7 it is and remains responsible for (where relevant, procuring) health and safety compliance at the Sites and shall use best endeavours to ensure that all Personnel, when working at the Sites, comply with all UK health, safety and environment legislation and approved codes of practice; and
 - 10.2.8 insofar as any Site is occupied by an Affiliate of the Provider or any other third party from time to time, the Provider shall be responsible for ensuring that where any provision in this Agreement imposes an obligation on the Provider to do or refrain from doing a particular thing in relation to a Site or any DER at such Site, the relevant Affiliate or third party complies with that obligation as if it were the named "Provider" party to this Agreement.
 - 10.2.9 it shall take all reasonable steps to achieve commissioning of the DER project on time and in accordance with the construction schedule.
- 10.3 Without prejudice to any right or remedy, each Party will be entitled to claim damages from the other Party for any breach of warranty set out herein.

11. CHARGES AND PAYMENT

Unless any alternative provision is explicitly stated in Schedule 2 the provisions in this Clause 11 shall be adhered to.

- 11.1 The Company agrees to pay the Charges to the Provider as full remuneration for the satisfactory performance by the Provider of the Flexibility Services in accordance with this Agreement.
- 11.2 The Charges shall be calculated by the Provider in accordance with Schedule 2.
- 11.3 The Provider will supply to the Company an invoice, or where applicable, a confirmation of acceptance against an invoice issued by the Company for the Charges within thirty (30) Business Days of the end of the month to which such invoice refers.
- 11.4 In the event that the Company requires the Provider to perform any Discretionary Flexibility Services, the Provider shall issue invoices on a monthly basis for any such services completed in the preceding month.
- 11.5 The Provider agrees that each invoice issued or accepted by it will include details of, as regards the Flexibility Services to which the invoice relates:
- a) the date on and time at which the Flexibility Services were provided;
 - b) the relevant Availability Fee details (if any); and
 - c) the relevant Utilisation Fee details (if any).
- 11.6 The Company shall not be held responsible for late payment of any invoices where the foregoing provisions relating to submission are not followed by the Provider.
- 11.7 The Company shall pay the Charges within thirty (30) days of receipt of the relevant invoice (the “**Due Date for Payment**”).
- 11.8 Unless otherwise agreed in writing between the Company and the Provider, payment of invoices shall be made by the Company either (at the Company’s option) by BACS payment to a bank account nominated in writing by the Provider or by cheque sent to an address nominated in writing by the Provider (or, where no such address is nominated in writing by the Provider then to the Provider’s registered office).
- 11.9 If the Company intends to pay less than the sum stated as due by the Company in the invoice it shall, not later than five (5) Business Days before the Due Date for Payment, give the Provider notice of that intention by issuing a notice which shall specify both the sum that it considers to be due to the Provider at the date the notice is given, or the sum which it considers is due from the Provider to the Company, and the basis on which that sum is calculated.
- 11.10 If either Party fails to make any payment due to the other under this Agreement by the Due Date for Payment, then the Party failing to pay shall pay interest on the overdue amount at a rate of two per cent (2%) per annum above the Bank of England base rate from time to time. Such interest shall accrue on a daily basis from the due date until actual payment of the overdue amount, whether before or after judgment. The relevant Party shall pay the interest together with the overdue amount. The Parties acknowledge that their liability under this Clause 11.10 is a substantial remedy for the purposes of section 9(1) of the Late Payment of Commercial Debts (Interest) Act 1998.
- 11.11 Where the either Party disputes any invoice (or any part of any invoice) then, upon receipt by the Provider of notification from the Company of any such disputed amounts, the provisions of Clause 23 shall apply in resolving the disputed amounts.

- 11.12 In the event that the Company disputes whether certain amounts contained in an invoice are properly due but does not dispute all sums contained in the invoice, the Company shall pay the sums not in dispute in accordance with the terms of this Agreement notwithstanding that the Company is disputing the other sums contained in the invoice.
- 11.13 Where either Party disputes any invoice (whether in whole or in part), interest under Clause 11.10 is payable only after the dispute is resolved, and only on those sums found or agreed to be due following resolution of the dispute, from the due date until payment.
- 11.14 All payments and all other sums referred to in this Agreement are stated exclusive of VAT. Where applicable, VAT shall be payable by the payer to the payee only upon receipt of a valid VAT invoice.
- 11.15 Where, during the Term, the Provider wishes to change its bank details or address for payment, then the Provider must follow the provisions set out in Clause 21.

12. TERMINATION

- 12.1 Each of the Parties shall have the right, if it is not the Party in breach or in relation to which any of the events concerned occurs, to immediately terminate this Agreement on giving written notice of termination to the other if at any time during the Term of this Agreement:
- 12.1.1 a Party is in material and/or persistent breach of this Agreement;
- 12.1.2 in relation to the Party to which the notice is addressed:
- a) a notice is issued to convene a meeting for the purpose of passing a resolution, or any written resolution is circulated, to wind it up, or such a resolution is passed other than a resolution for its solvent reconstruction or reorganisation;
 - b) a resolution is passed by its directors to seek a winding up, or a petition for a winding up order is presented against it, or such an order is made;
 - c) a receiver, administrative receiver, receiver and manager, interim receiver, custodian, sequestrator, administrator or similar officer is appointed in respect of that Party or over a substantial part of its assets, or any steps are taken to appoint such an officer in respect of that Party, or an encumbrancer takes steps to enforce or enforces its security, or any distress, attachment, sequestration or execution or other similar process affects any of its assets and is not discharged within fourteen (14) days;
 - d) a proposal for a voluntary arrangement is made in relation to it under Part I of the Insolvency Act 1986;
 - e) it takes any step (including starting negotiations) with a view to readjusting, rescheduling or deferring any part of its indebtedness, or it proposes or makes any general [assignment, **Note: if English**] [assignment, **Note: if Scottish**] composition or arrangement with or for the benefit of all or some of its creditors (other than for the sole purpose of a solvent amalgamation or solvent reconstruction), or it makes or suspends or threatens to suspend making payments to all or some of its creditors or it submits to any type of voluntary arrangement;
 - f) it is deemed to be unable to pay its debts within the meaning of section 123 of the Insolvency Act 1986;
 - g) any step or event is taken or arises outside the United Kingdom which is similar or analogous to any of the steps or events listed at 12.1.2a) to 12.1.2f) above;

- h) it suspends or ceases, or threatens to suspend or cease, to carry on all or a substantial part of its business;
- i) any of the events in 12.1.2b) to 12.1.2j) above occurs in relation to any of its Affiliates; and
- j) Clause 16.4 of this Agreement applies.

12.2 Either Party may terminate this Agreement at any time by providing ninety (90) days written notice to the other Party.

Accrued liabilities

12.3 On termination, the rights and liabilities of the Parties that have accrued before termination shall subsist.

Surviving provisions

12.4 This Clause and the following provisions of this Agreement shall survive termination or expiry, without limit of time:

- 12.4.1 Clause 1 (*Definitions and interpretation*);
- 12.4.2 Clause 7 (*Records and Audit*);
- 12.4.3 Clause 11 (*Charges and Payment*);
- 12.4.4 Clause 12.5 (*Consequences of Termination or Expiry*);
- 12.4.5 Clause 13.4 (*Service Failure and Material Breach*);
- 12.4.6 Clause 15 (*Indemnity & Liability*);
- 12.4.7 Clause 17 (*Confidentiality*);
- 12.4.8 Clause 18 (*Intellectual Property Rights*);
- 12.4.9 Clause 20 (*Data Protection*);
- 12.4.10 Clause 23 (*Dispute Resolution*);
- 12.4.11 Clause 27 (*Waiver*); and
- 12.4.12 Clause 30 (*Governing Law and Jurisdiction*).

Consequences of termination or expiry

12.5 Unless otherwise agreed, on expiry or termination of this Agreement each Party shall within two (2) months remove and return to the other Party any equipment at its Site(s) provided by the other Party for the purpose of the Agreement. Should the Provider fail to return such equipment the Company may enter the Provider's Site and recover the same and the Provider shall allow the Company reasonable access to do so, in which case the Provider shall reimburse to the Company the reasonable costs incurred by the Company.

12.6 Where requested by the other Party, on termination or expiry of this Agreement each Party shall delete or return Confidential Information provided by the other Party for the purpose of the Agreement.

- 12.7 Following termination or expiry of this Agreement, the Provider shall promptly at the Provider's cost:
- 12.7.1 deliver to the Company for approval a final invoice detailing all monies due to it under the Agreement;
 - 12.7.2 submit to the Company within thirty (30) Business Days all invoices with supporting documents for payment of all outstanding sums in connection with the provision of the Flexibility Services.

13. SERVICE FAILURE AND MATERIAL BREACH

- 13.1 Notwithstanding its obligations under Clause 13.2, the Provider shall notify the Company as soon as reasonably practicable upon becoming aware of the inability (howsoever caused) of the Provider to provide the Flexibility Services in all or any part of any Service Window.
- 13.2 In the event of a Service Failure by the Provider, the Company may require the Provider to:
- a) provide the Company with a written explanation as to the cause of the failure of service delivery;
 - b) implement a rectification plan for improving performance and/or reducing the number of occurrences of Unavailability, which may include at the Company's discretion, a repeat of any commissioning tests undertaken on initial installation and commissioning of the DER;
 - c) propose a variation to the Service Requirements as specified in Schedule 1; or
 - d) take any other action that may be specified by the Company in order to alleviate a Service Failure (as reasonably required in the circumstances).
- 13.3 If the Provider fails to comply with the terms of Clause 13.2, or the Provider's performance in respect of the Service Failure notified by the Company does not significantly improve within thirty (30) days of the date of the notice, such failure will be deemed a material breach of this Agreement for the purposes of Clause 12.1.
- 13.4 Where the Company terminates this Agreement as a result of a material and/or persistent breach by the Provider under Clause 12.1, the Company shall be entitled to recover from Provider the additional cost, Loss and expense reasonably incurred by the Company as a result of the termination, including where relevant appointing a replacement Provider, the amount of this, Loss shall be a debt due and immediately payable by the Provider to the Company.

14. FORCE MAJEURE

- 14.1 A Party is not in breach or default of this Agreement to the extent that it is prevented, hindered or delayed in performing any of its obligations under this Agreement as a result of a Force Majeure Event.
- 14.2 If a Force Majeure Event occurs, the following process will apply:
- (a) The affected Party will notify the other Party as soon as reasonably practicable of:
 - (i) The occurrence and description of the Force Majeure Event;
 - (ii) The date on which the Force Majeure Event commenced and its likely duration (if known);

- (iii) The effect of the Force Majeure Event on the Party's ability to perform its obligations under the Agreement.
 - (b) The affected Party will use reasonable endeavours to mitigate the impact of the Force Majeure Event on its ability to perform its obligations under the Agreement.
- 14.3 If a Force Majeure Event prevents, hinders or delays a Party in performing its obligations under the Agreement for a continuous period of at least eight (8) weeks, either Party may terminate the Agreement on giving ninety (90) days written notice.

15. INDEMNITY & LIABILITY

- 15.1 The Company relies upon the Provider exercising the standard of care set out in Clause 9 in the performance of the Flexibility Services and their obligations hereunder and upon the accuracy of all representations and statements made and advice given by the Provider in connection with this Agreement.
- 15.2 Subject to Clause 15.4 the Provider shall indemnify the Company against all Loss, damage, costs, legal costs, professional and other expenses of any nature whatsoever incurred or suffered by the Company as a result of:
 - 15.2.1 the Provider's breach of this Agreement;
 - 15.2.2 any negligence or reckless act or omission committed by the Provider in the course of providing the Flexibility Services;
 - 15.2.3 Loss or damage to any property (including property of the Company); or
 - 15.2.4 all related actions, suits, claims, demands, costs, charges or expenses to the extent that the same is caused by any negligent act or omission or breach of statutory duty, regulation or by-law by the Provider, its sub-consultants or their respective servants or agents in connection with this Agreement.
- 15.3 Subject to Clause 15.4 the Company shall be responsible for the Provider in respect of liability for personal injury to or death of any person to the extent that the same is caused by any negligent act or omission or breach of statutory duty by the Company, his employees or their respective agents in connection with this Agreement.
- 15.4 Notwithstanding any other provision in this Agreement, the aggregate total liability of either Party to the other Party under or in connection with this Agreement whether in contract tort or delict or howsoever arising shall from time to time be limited to the aggregate total charges payable or paid to the Provider under this Agreement. This Clause shall not limit or exclude either Party's liability:
 - 15.4.1 in the case of fraud, misrepresentation or wilful misconduct;
 - 15.4.2 in the case of death or personal injury;
 - 15.4.3 in the case of breach of statutory duty; or
 - 15.4.4 where the Provider has invalidated such insurance referred to in Clause 8 or has not complied with such insurance policies.
- 15.5 Notwithstanding anything to the contrary neither Party shall have any liability to the other Party under this Agreement for any indirect or consequential loss of any kind howsoever caused.

16. [ASSIGNMENT, NOTE: IF ENGLISH] [ASSIGNATION, NOTE: IF SCOTTISH] SUB-CONTRACTING AND CHANGE IN OWNERSHIP

- 16.1 This Agreement is personal to the Parties and neither Party shall assign, transfer, mortgage, charge, sub-contract or deal in any other manner with any or all of its rights and obligations under this Agreement without the prior written consent of the other Party (such consent not to be unreasonably withheld, conditioned or delayed).
- 16.2 If either Party sub-contracts any part of the provision or obligations of Flexibility Services, then the responsible Party shall be fully responsible for the acts, omissions or defaults of any sub-contractor (and its employees) as if they were the acts, omissions or defaults of the responsible Party.
- 16.3 If ownership, occupancy or use (for the purpose of providing the Flexibility Services) of any Provider Site changes, or may change, during the Term, the Provider shall immediately notify the Company of the same. The Company and the Provider shall promptly meet (via phone or in person, at the reasonable request of the Company) to discuss the implications of the change and the options available to minimise any disruption that may be caused by the change.
- 16.4 The Company reserves the right to terminate this Agreement if a Change in Ownership of the Provider occurs and may treat a Change of Ownership as a material breach for the purposes of Clause 12.1.

17. CONFIDENTIALITY

- 17.1 In application of this Clause 17, the words “Company” and “Provider” shall include not only the Parties themselves, but also their respective employees as well as all other natural or legal persons and any subcontractor commissioned by either one of the Parties.
- 17.2 Subject to Clause 17.6, any information disclosed by either Party in connection with this Agreement shall be treated as confidential (“**Confidential Information**”). The recipient Party agrees:
- 17.2.1 to treat such Confidential Information as confidential and not disclose it to third parties;
 - 17.2.2 to restrict the use of such Confidential Information to matters relating to the recipient Party’s performance under this Agreement; and
 - 17.2.3 to restrict access to such information to employees of the recipient Parties whose access is necessary in the implementation of this Agreement.
- 17.3 Neither Party shall use the name, brands and/or logos of the other Party for any purpose without the other Party’s prior written approval. In the event that the other Party grants its approval to any use of its name, brand and/or logo, it may make such approval subject to such conditions and restrictions on use as it considers appropriate. Written approval should not be unreasonably withheld.
- 17.4 No Party shall have any liability to the other Party in connection with any information:
- 17.4.1 that was in the possession of the Receiving Party free of any obligation of confidentiality, or was in the public domain, at the time the Disclosing Party communicated it to the Receiving Party;

- 17.4.2 that is disclosed to a third party with the prior written approval of the Disclosing Party, provided that such approval shall permit only a specified disclosure and may not be relied upon as authority for any other disclosures;
 - 17.4.3 that is independently developed by personnel, or agents of the Receiving Party without reliance on or recourse to the Disclosing Party's Confidential Information;
 - 17.4.4 that must be disclosed pursuant to requirements of law or valid legal process, provided that the Party intending to make disclosure in response to such requirements or process shall promptly notify the Disclosing Party in advance of any such disclosure and reasonably cooperate in attempts to maintain the confidentiality of the Confidential Information; or
 - 17.4.5 that is disclosed to insurers and/or insurance brokers.
- 17.5 The Provider shall treat this Agreement as private and confidential and shall not make any written or verbal statement to any press, news or media, publish alone or in conjunction with any other person any information concerning this Agreement without the prior written consent of the Company.
- 17.6 Notwithstanding the foregoing, the Provider acknowledges and agrees that:
- 17.6.1 that the Company may be involved in industry initiatives, commitments and data accessibility obligations in relation to network constraint management and electricity network optimisation. It shall not be a breach of this Clause 17 for the Company to share information for such industry initiatives in relation to Flexibility Services in the Zone, provided the information is suitably anonymised; and
 - 17.6.2 the Company shall be entitled to make publicity releases and/or announcements regarding either this Agreement and/or the Company's activities under this Agreement.
- 17.7 The Parties intend that all information exchanged or obtained by the Parties shall be treated as confidential and held in strict confidence during the Term of this Agreement and for a period of seven (7) years thereafter.

18. INTELLECTUAL PROPERTY RIGHTS

- 18.1 This Agreement does not transfer any interest in Intellectual Property Rights.
- 18.2 All Intellectual Property Rights owned by or licensed to either Party shall at all times both during the Term of the Agreement and after its termination or expiry, belong to or be licensed to the Party providing that intellectual property and neither Party shall make any use of the other Party's Intellectual Property other than to the extent reasonably necessary in performing its obligations pursuant to this Agreement, provided that nothing in this Clause 18 shall operate so as to exclude any non-excludable rights of either Party.

19. COMPANY PROPERTY

- 19.1 Each Party shall retain its rights in its own physical property used for the purposes of this Agreement. Any equipment, tools, drawings, specifications, data and other materials supplied by or on behalf of the Company to the Provider:
- 19.1.1 shall at all times be and shall remain the exclusive property of the Company;

- 19.1.2 shall be held by the Provider in safe custody at its own risk and maintained and kept in good condition by the Provider until returned by the Company;
- 19.1.3 shall be marked visibly by the Provider as the property of the Company; and
- 19.1.4 shall not be disposed of other than in accordance with the written instructions of the Company nor used otherwise than as authorised by the Company in writing.

20. DATA PROTECTION

- 20.1 Each Party shall, at its own expense, ensure that it complies with all applicable Data Protection Law.
- 20.2 The Parties acknowledge that as at the date of this Agreement, neither Party acts as a processor on behalf of the other. If at any point during the term, either Party considers that one Party is acting as processor on behalf of the other, then the Parties shall promptly meet to negotiate in good faith a separate data processing agreement to cover the matters required by the Data Protection Law.

21. MODERN SLAVERY, ANTI-BRIBERY AND LIVING WAGE

- 21.1 The Provider undertakes, warrants and represents that:
 - 21.1.1 neither the Provider nor any of its officers, employees, agents or subcontractors:
 - a) has committed an offence under the Modern Slavery Act 2015 (“**MSA Offence**”);
 - b) has been notified that it is subject to an investigation relating to an alleged MSA Offence or prosecution under the Modern Slavery Act 2015; or
 - c) is aware if any circumstances within its supply chain that could give rise to an investigation relating to an alleged MSA Offence or prosecution under the Modern Slavery Act 2015.
 - 21.1.2 it shall comply with all applicable anti-slavery and human trafficking laws, statutes, regulations and codes from time to time in force including but not limited to the Modern Slavery Act 2015;
 - 21.1.3 it shall notify the Company immediately in writing if it becomes aware or has reason to believe that it, or any of its officers, employees, agents or subcontractors have breached or potentially breached any of the Company’s obligations under this Clause 21. Such notice to set out full details of the circumstances concerning the breach or potential breach of Provider’s obligations; and
 - 21.1.4 it shall include in its contracts with its subcontractors and suppliers’ anti-slavery and human trafficking provisions that are at least as onerous as those set out in this Clause 21.
- 21.2 The Provider shall indemnify the Company against any Losses, incurred by or awarded against the Company as a result of any breach of anti-slavery and human trafficking laws, statutes, regulations and codes or the Modern Slavery Act 2015.
- 21.3 Any breach of this Clause 21 by the Provider shall be deemed a material breach of the Agreement for the purposes of Clause 12.1.
- 21.4 The Provider shall have suitable controls and compliance procedures in place and shall not engage in any activity, practice or conduct which would constitute an offence under the Bribery

Act 2010 and shall promptly report to the Company any request or demand for any undue financial or other advantage of any kind received or offered by the Provider in connection with this Agreement.

21.5 The Provider agrees to:

21.5.1 pay all of its personnel who are directly employed by it in respect of the provision of the Services; and

21.5.2 ensure all employees of its contractors and subcontractors performing the provision of the Services are paid not less than the living wage for the Term of this Agreement.

22. NOTICES

22.1 The processes for notices and communications in respect of operational matters are set out in Schedule 4.

22.2 All formal notices or other communications to be served under this Agreement (“**Non-Operational Notice**”) shall be given in writing and shall be delivered or sent to the addresses for notice set out in Part 1 of the Flexibility Services Agreement or to such other address as each Party may have notified in writing to the other Party.

22.3 A Non-Operational Notice shall be delivered by hand, sent by pre-paid first-class post, or by recorded delivery post (or equivalent recorded postal delivery service).

22.4 A Non-Operational Notice or other communication shall be deemed to have been received:

22.4.1 if delivered by hand or recorded delivery post within Business Hours at the time of delivery or, if delivered by hand outside Business Hours, at the next start of Business Hours;

22.4.2 if sent by first class post, at 9.00 a.m. on the second Business Day after posting.

22.5 E-mail communications may be valid for Non-Operational Notices the purposes of this Agreement, where agreed between the Parties. Such email notices shall be deemed to have been received on the day of sending, or where outside of Business Hours on the first Business Day thereafter.

22.6 In verifying service of a Non-Operational Notice, it shall be sufficient to prove that delivery was made or that the envelope containing the notice was properly addressed and posted.

22.7 This Clause does not apply to the service of any legal proceedings, or other documents in any legal action or other method of dispute resolution.

23. DISPUTE RESOLUTION

23.1 The Parties shall use good faith efforts to resolve any operational issue, dispute, claim or proceeding arising out of or relating to this Agreement. In the event that a dispute cannot be resolved within thirty (30) days of written notice of the dispute, the dispute shall be escalated to the Parties’ senior representatives (named in Schedule 4, or as otherwise notified by either Party to the other) who have authority to settle the same.

23.2 If thirty (30) days following such an escalation the Parties have still not resolved the dispute, then either Party shall have the right to refer the dispute to mediation or to commence proceedings.

23.3 Nothing in this Agreement shall prevent either Party from raising Court proceedings in order to preserve or enforce its proprietary or other rights.

24. SEVERANCE

24.1 If any provision of this Agreement is declared by a judicial or other competent authority to be wholly or partly void, voidable, illegal or otherwise unenforceable in whole or in part, that provision (or part provision) shall be deemed severed from this Agreement and the other provisions of this Agreement and the remainder of the relevant provision shall continue in full force and effect.

24.2 If any provision of this Agreement are so found to be wholly or partly invalid or unenforceable, but would be valid or enforceable if some part of the provision were deleted, restricted or limited in a particular manner, the provision in question shall apply with the minimum deletions, restrictions or limitations as may be necessary to make it valid or enforceable.

24.3 The Company and the Provider each acknowledge that it has entered into this Agreement on an arm's length basis and that it has taken independent legal advice in so doing.

25. THIRD PARTY RIGHTS

25.1 For the purposes of the Contracts (Rights of Third Parties) Act 1999 or where appropriate the Contracts (Third Party Rights) (Scotland) Act 2017, this Agreement are not intended to, and do not, give any person who is not a party to it any right to enforce any of its provisions other than the Distribution and Transmission Licensees (the Company) who shall be entitled to independently enforce all of the terms of this Agreement.

25.2 The Provider agrees that it shall not enter into any arrangements with third parties that conflict or are inconsistent with the provision of the Flexibility Services under this Agreement without the prior written consent of the Company.

26. NO AGENCY OR PARTNERSHIP

26.1 Nothing in this Agreement shall be deemed to constitute a partnership or joint venture or contract of employment between the Parties nor constitute either Party the agent of the other.

26.2 Neither Party shall act or describe itself as the agent of the other, nor shall it make or represent that it has authority to make any commitments on the other's behalf, including but not limited to the making of any representations or warranty and the exercise of any right or power.

27. WAIVER

27.1 If a Party delays or fails to exercise (in whole or part) any right, claim or remedy conferred by or arising under or in connection with this Agreement or by law, this will not operate as a waiver of, or as preventing the further exercise or the enforcement of, that right, claim or remedy. Any single or partial exercise or waiver of any such right, claim or remedy shall not preclude its further exercise or the exercise of any other right, claim or remedy.

27.2 A waiver of any right, claim or remedy conferred by or arising under or otherwise in connection with this Agreement or by law shall be effective only if it is given in writing and is signed by or on behalf of the Party giving it.

28. ENTIRE AGREEMENT

28.1 This Agreement and the documents referred to in it together constitute the entire agreement and understanding of the Parties relating to the matters contemplated by this Agreement and those documents, and supersede any previous drafts, agreements, understandings or arrangements between any of the parties relating to the subject matter of this Agreement and those documents, which shall cease to have any further effect.

29. COUNTERPARTS

29.1 Where executed in counterparts:

29.1.1 This Agreement shall not take effect until all of the counterparts have been delivered; and

29.1.2 delivery will take place when the date of delivery is agreed between the Parties after execution of this Agreement as evidenced by the date inserted at the start of this Agreement.

29.2 Where not executed in counterparts, this Agreement shall take effect after its execution upon the date agreed between the Parties as evidenced by the date inserted at the start of this Agreement.

30. GOVERNING LAW AND JURISDICTION

30.1 The validity, construction and performance of this Agreement and any claim, dispute or matter (whether contractual or non-contractual) arising under or in connection with this Agreement or its enforceability shall be governed by and construed: (i) in accordance with English law if the Company is incorporated in England and Wales; and (ii) in accordance with Scots law if the Company is incorporated in Scotland.

30.2 Each Party irrevocably submits to the exclusive jurisdiction of the courts of: (i) England and Wales if the Company is incorporated in England and Wales; and (ii) Scotland if the Company is incorporated in Scotland, over any claim, dispute or matter arising under or in connection with this Agreement or its enforceability or the legal relationships established by this Agreement (including non-contractual disputes or claims) and waives any objection to proceedings being brought in such courts or on the grounds that proceedings have been brought in an inconvenient forum.

.....

**SCHEDULE 1
SERVICE DESCRIPTION**

Permitted Extensions:

Extension Periods:

[Part 1]

[Service Parameters]

Criteria	Contracted Service detail
<i>Type of Service (sustain, dynamic, secure, restore)</i>	
<i>Zone</i>	
<i>Flexible Unit ID</i>	
<i>Contract Start Date</i>	
<i>Contract End Date</i>	
<i>Contracted Service Capacity (MW/MVAR)</i>	
<i>Contracted Service Windows (if specified)</i>	
<i>Contracted Response Time (if specified)</i>	
<i>Service Recovery Time (if specified)</i>	

<i>Service Minimum run-time (if specified)</i>	
<i>Maximum Utilisations (per Service Window)</i>	

Service Failure

Service Failure
<p><i>Any response provided below 65% of contracted service.</i></p> <p><i>Further details in Schedule 5.</i></p>

[Part 2]

[Service Windows]

<i>Service Period</i>	<i>Delivery Season</i>	<i>[●]</i>
	<i>Service Window 1 From</i>	<i>[●]</i>
	<i>Service Window 1 To</i>	<i>[●]</i>
	<i>Service Window 2 From</i>	<i>[●]</i>
	<i>Service Window 2 To</i>	<i>[●]</i>

[Part 3]

[Service Requirements]

1.	<i>The flexible facilities making up the DER shall be connected and capable of exporting to or importing from the area of the Network asset(s) subject to the limitation (represented by the zone) during intact and under first circuit outage of that network asset(s).</i>
2.	<i>Exporting generators and storage assets, greater than [16A] per phase shall have a long-term parallel connection compliant with the requirements of EREC G59 or G99. Flexible or timed connections are permissible, subject to the conditions of the connection. Those less than [16A] per phase shall be compliant with the requirements of EREC G83 or G98.</i>
3.	<i>The DER shall be able to deliver on instruction a reduction in imports or an increase in export, from or onto the Network.</i>
4.	<i>The flexible MW is the volume of additional consumption or generation that can be adjusted flexibly relative to a defined baseline level. It shall be at least [50kW] from one or more facilities making up the DER, can be delivered reliably and in full, is fixed for the duration of the service period, and must be within the conditions of each Facility's connection agreement.</i>
5.	<i>The DER shall have a single set of capability parameters, and shall be a single point of communication and control.</i>
6.	<i>Each facility making up the DER shall have half hourly metering of sufficient accuracy to enable the Company to monitor the provision of Flexibility Services. The data shall be made available to the Company on request and at the end of every month. The metering point shall be at the boundary between the Site on which the DER is located and the [distribution] Network, or on the terminals of the facility if approved by the Company. The Provider should be able to provide technical details of the meter and a single line diagram of the DER on request.</i>
7.	<i>The DER can run for other purposes during the Service Window, subject to it not increasing demand on the network. It is the responsibility of the Provider to ensure that they can deliver the contracted Flexibility Services on instruction.</i>
8.	<i>Where sites are contracted to deliver Flexibility Services; there is an understanding that there may be a requirement for recovery following service delivery. In the event that a response is triggered but a site's maximum response duration is less than the total event period for the required response; the site should not excessively increase demand following the depletion of available Flexible Resources. An example of this would be that an Electricity Storage system once depleted should not instantly recharge if the trigger signal is still active, as this may compound existing network issues. The</i>

	<p><i>Company reserve the right to terminate Flexibility Service contracts if Providers are seen to demonstrate activities such as that detailed above where they are seen to compound an existing network issue.</i></p>
<p>9.</p>	<p><i>Suppliers should not demonstrate any practices which could be deemed as gaming the system. Examples of gaming the system would include (not an exhaustive list): where a site has multiple supplies and they are viewed to reduce demand on one to provide a contracted Flexible Service but then move the demand to an alternative supply fed from the Company's network; artificially increasing Demand or encouraging others to artificially increase Demand to stimulate the Company to trigger a Flexible Service; any acts of vandalism or sabotage which may stimulate the Company to trigger a Flexible Service.</i></p>

**SCHEDULE 2
FLEXIBILITY SERVICE CHARGES**

[Note: Schedule to be amended as appropriate]

Invoicing

All invoices should reference the statement number and be sent to the Nominated Person as identified in Part 1 of this Agreement.

[Note: Provide any further commentary in respect of specific payment processes/invoices]

Charges

Utilisation Fee	Availability Fee	Values/prices	Discretionary Utilisation Fee

Calculation of Charges

Calculation formula	Payment mechanism	Values/prices	Baseline for measuring delivery	Timing of payments

Reduction of charges

In accordance with Schedule 5 – Performance monitoring.

Withholding and recovery of payments

**SCHEDULE 3
SITES/DER**

[Note: Schedule to be amended as appropriate]

[Note: List Provider's assets and facilities approved to deliver the service(s) per Flexibility Service]

[DER Name]	Type (Solar, Hydro, Battery Storage, DSR, etc)	
	Location (address)	
	MPAN	
	Contact details for site (Name, number, email address)	
	Capacity (MW/MWh)	
	Planned maintenance periods	
	Notice period required for access	

**SCHEDULE 4
COMMUNICATIONS**

[Note: Schedule to be amended as appropriate]

Senior Representatives:

Process and systems for communications

Utilisation Instructions	Stop Instructions	Unavailability notices	Discretionary Utilisation Request
<p>FSD* Closed Contact = Engage Service Provider should start delivery and send a steady 24V signal via the Delivery in progress indication (DIP*) control.</p> <p>Where there are comms issues utilising the RTU; a verbal instruction will be issued by Electricity North West's Network Management Hub.</p>	<p>FSD* Open Contact = Disengage service Provider should stop delivery and send a 0V signal via the Delivery in progress indication (DIP*) control.</p> <p>Where there are comms issues utilising the RTU; a verbal instruction will be issued by the Network Management Hub.</p>	<p><i>Form on following page</i></p>	<p>FSD* Closed Contact outside of contractual window = Engage Service if able and willing to.</p> <p>Provider should start delivery and send a steady 24V signal via the Delivery in progress indication (DIP*) control.</p> <p>Stop instructions will be in the same form as Contractual window period.</p> <p>Where there are comms issues utilising the RTU; a verbal instruction will be issued by the Network Management Hub.</p>

*A diagram of contacts is shown in Schedule 4 figure 1

Figure 1: Diagram of communication signalling

Flexible Services Dispatch – Customer Interface Controls

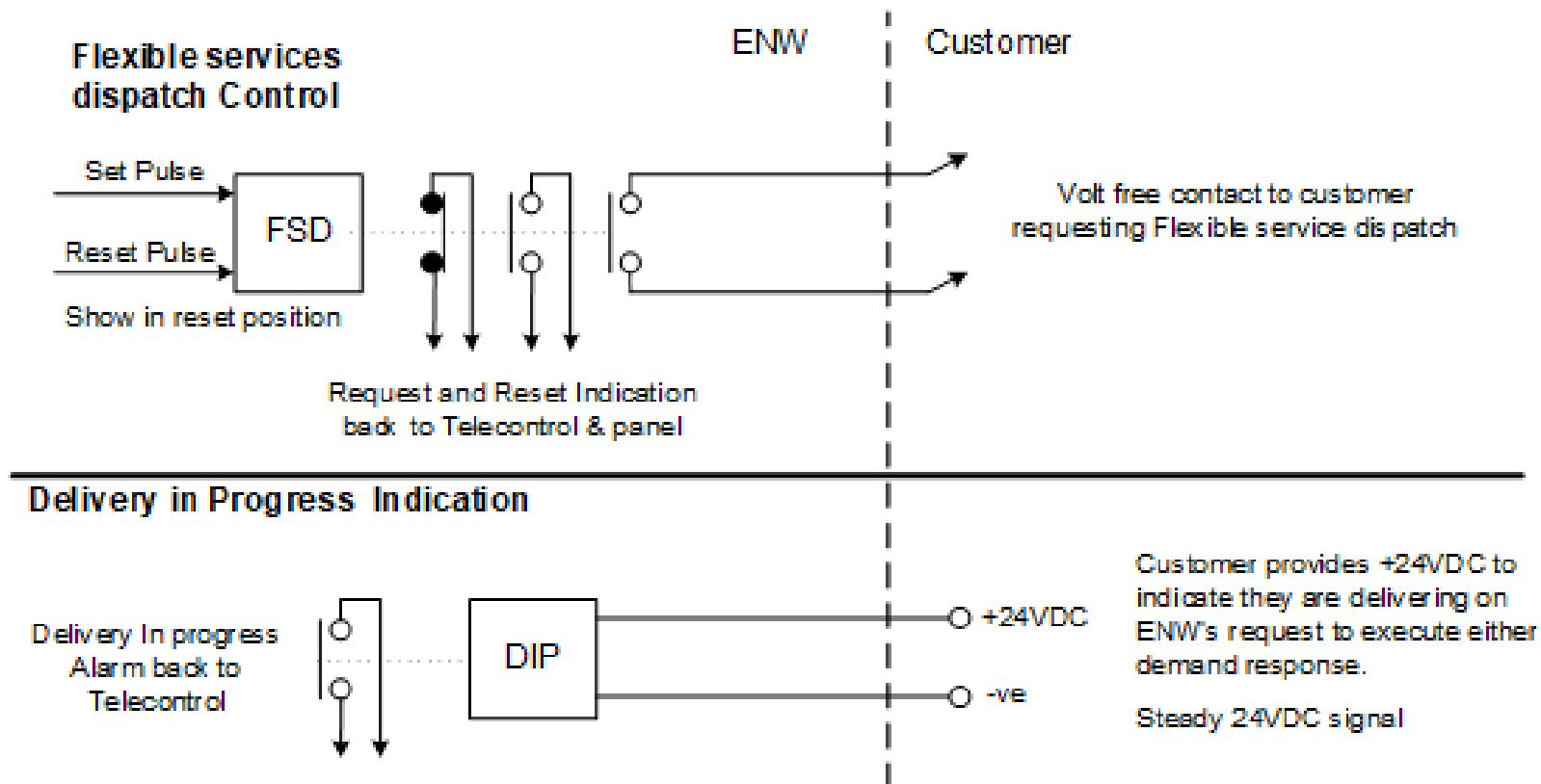

Escalations process

<i>Escalation Level</i>	<i>Company Representative</i>	<i>Service Provider Representative</i>
1	<i>Relevant Company Authorised Person</i>	[●]
2	<i>Relevant Company Manager/Commercial Manager</i>	[●]
3	<i>Relevant Company Performance Manager</i>	[●]

[FORM OF UNAVAILABILITY NOTIFICATION / REMEDY NOTIFICATION]

[In accordance with Clause 3.1, this is a notification of Unavailability of Flexibility Services.]

<i>Company Name:</i>	
<i>Zone ID:</i>	
<i>Flexible Unit:</i>	
<i>From Date/Time:</i>	<i>[Unavailable from]</i>
<i>To Date/Time:</i>	<i>[Unavailable to]</i>
<i>Reason:</i>	
<i>Name:</i>	<i>[of individual making notification]</i>
<i>Date:</i>	<i>[of notification]</i>

**SCHEDULE 5
PERFORMANCE MONITORING**

[Note: Schedule to be amended as appropriate]

Submission of Performance Report

[Note: Set out how Provider shall submit the Performance report]

Testing and monitoring

Testing will be conducted at least 1 month prior to the beginning of the contracted delivery window.

Response provided as % of contracted service	Payment	Actions
>100%	No additional payment made for services greater than requested	None
100% - 65%	Payment proportionate to service delivered	Service delivery under 90% will be monitored. Greater than three utilisations delivered at <90% will be constituted as service failure.
<65%	Service failure. No payment made.	Potential contract termination

Service Meter

Measuring equipment	Service Meter Data
<i>Half hourly metering</i>	<i>[Note: Define Service Meter Data]</i>

Monitoring of DER development projects

Detailsof development milestone	Expected date of delivery	Comments
<i>[Note: Provide information as appropriate]</i>	<i>[Note: Provide information as appropriate]</i>	<i>[Note: Provide information as appropriate]</i>

The Company may repeat the assessment process on an annual basis.]

Auditing

Process	Requirements
<i>[Note: Provide information as appropriate]</i>	<i>[Note: Provide information as appropriate]</i>

**SCHEDULE 6
SPECIAL REQUIREMENTS**

[Note: Schedule to be amended/deleted as appropriate]

[Note: Schedule included for any specific variations, specific HSE requirements or obligatory additions of the Company]